

# DKDF/CP NC - Pneumatically actuated 2-way diaphragm valve PN 10 DN 15:65

Pneumatically actuated diaphragm valve with male ends for socket fusion, metric series. Normally Closed function.

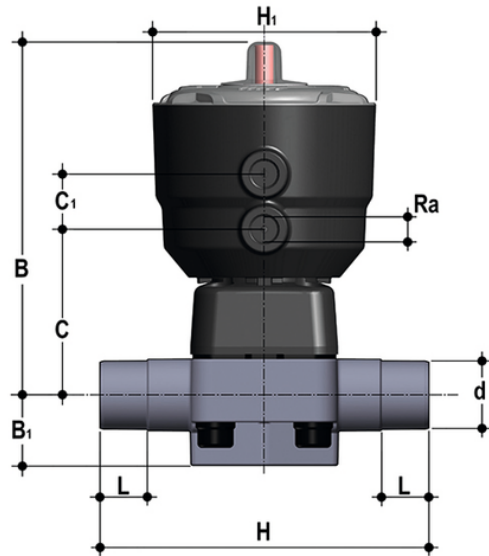

## EPDM

Reference	tooltiplmage	system	Category	family	series	d	DN	PN	B	B <sub>1</sub>	C	C[5:1]	H	H <sub>1</sub>	L	R[5:α]	g
DKDFNC020E	-	Automation system	Pneumatically actuated valves	Diaphragm valves	DK/CP DN 15÷65	20	15	10	148	25	66	24	124	97	16	1/4"	732
DKDFNC025E	-	Automation system	Pneumatically actuated valves	Diaphragm valves	DK/CP DN 15÷65	25	20	10	151	30	69	24	144	97	19	1/4"	762
DKDFNC032E	-	Automation system	Pneumatically actuated valves	Diaphragm valves	DK/CP DN 15÷65	32	25	10	159	33	78	24	154	97	22	1/4"	991
DKDFNC040E	-	Automation system	Pneumatically actuated valves	Diaphragm valves	DK/CP DN 15÷65	40	32	10	163	30	82	24	174	97	26	1/4"	1052
DKDFNC050E	-	Automation system	Pneumatically actuated valves	Diaphragm valves	DK/CP DN 15÷65	50	40	10	207	35	112	24	194	126	31	1/4"	2862
DKDFNC063E	-	Automation system	Pneumatically actuated valves	Diaphragm valves	DK/CP DN 15÷65	63	50	10	245	46	142	24	224	157	38	1/4"	6357

# DKDF/CP NC – Pneumatically actuated 2-way diaphragm valve

## PN 10 DN 15:65

Reference	tooltiplmage	system	Category	family	series	d	DN	PN	B	B <sub>1</sub>	C	C[5:1]	H	H <sub>1</sub>	L	R[5:α]	g
DKDFNC075E	-	Automation system	Pneumatically actuated valves	Diaphragm valves	DK/CP DN 15÷65	75	65	10	245	46	142	24	284	157	44	1/4"	6596

### FKM

Reference	tooltiplmage	system	Category	family	series	d	DN	PN	B	B <sub>1</sub>	C	C[5:1]	H	H <sub>1</sub>	L	R[5:α]	g
DKDFNC020F	-	Automation system	Pneumatically actuated valves	Diaphragm valves	DK/CP DN 15÷65	20	15	10	148	25	66	24	124	97	16	1/4"	732
DKDFNC025F	-	Automation system	Pneumatically actuated valves	Diaphragm valves	DK/CP DN 15÷65	25	20	10	151	30	69	24	144	97	19	1/4"	762
DKDFNC032F	-	Automation system	Pneumatically actuated valves	Diaphragm valves	DK/CP DN 15÷65	32	25	10	159	33	78	24	154	97	22	1/4"	991
DKDFNC040F	-	Automation system	Pneumatically actuated valves	Diaphragm valves	DK/CP DN 15÷65	40	32	10	163	30	82	24	174	97	26	1/4"	1052
DKDFNC050F	-	Automation system	Pneumatically actuated valves	Diaphragm valves	DK/CP DN 15÷65	50	40	10	207	35	112	24	194	126	31	1/4"	2862
DKDFNC063F	-	Automation system	Pneumatically actuated valves	Diaphragm valves	DK/CP DN 15÷65	63	50	10	245	46	142	24	224	157	38	1/4"	6357
DKDFNC075F	-	Automation system	Pneumatically actuated valves	Diaphragm valves	DK/CP DN 15÷65	75	65	10	245	46	142	24	284	157	44	1/4"	6596

### PTFE

Reference	tooltiplmage	system	Category	family	series	d	DN	PN	B	B <sub>1</sub>	C	C[5:1]	H	H <sub>1</sub>	L	R[5:α]	g
DKDFNC020P	-	Automation system	Pneumatically actuated valves	Diaphragm valves	DK/CP DN 15÷65	20	15	10	148	25	66	24	124	97	16	1/4"	732
DKDFNC025P	-	Automation system	Pneumatically actuated valves	Diaphragm valves	DK/CP DN 15÷65	25	20	10	151	30	69	24	144	97	19	1/4"	762

# DKDF/CP NC – Pneumatically actuated 2-way diaphragm valve

## PN 10 DN 15:65

Reference	tooltiplmage	system	Category	family	series	d	DN	PN	B	B <sub>1</sub>	C	C[5:1]	H	H <sub>1</sub>	L	R[5:α]	g
DKDFNC032P	-	Automation system	Pneumatically actuated valves	Diaphragm valves	DK/CP DN 15÷65	32	25	10	159	33	78	24	154	97	22	1/4"	991
DKDFNC040P	-	Automation system	Pneumatically actuated valves	Diaphragm valves	DK/CP DN 15÷65	40	32	10	163	30	82	24	174	97	26	1/4"	1052
DKDFNC050P	-	Automation system	Pneumatically actuated valves	Diaphragm valves	DK/CP DN 15÷65	50	40	10	207	35	112	24	194	126	31	1/4"	2862
DKDFNC063P	-	Automation system	Pneumatically actuated valves	Diaphragm valves	DK/CP DN 15÷65	63	50	10	245	46	142	24	224	157	38	1/4"	6357
DKDFNC075P	-	Automation system	Pneumatically actuated valves	Diaphragm valves	DK/CP DN 15÷65	75	65	10	245	46	142	24	284	157	44	1/4"	6596

# DKDF/CP NC – Pneumatically actuated 2-way diaphragm valve

## PN 10 DN 15:65

The new compact and light piston actuator in PP-GR makes the DK/CP the ideal choice for applications requiring very frequent valve operation and a long valve lifetime.

- High visibility graduated optical position indicator protected by a transparent cap with a seal O-Ring.
- Compact and light piston in PP-GR, ideal for heavy-duty applications in chemically aggressive environments with a diaphragm perimeter containment system that ensures the perfect compression of the rubber without any lateral expansion.
- Piston in high strength IXEF®. The high quality finishing of the external surface guarantees perfect slidability over the seal and ensures a long working life without any actuator maintenance.
- High strength stainless steel stem with double seal O-Ring. Floating pin connection between the actuator stem and diaphragm to prevent concentrated loads, improve the seal and extend its lifetime.
- Actuator equipped with 6 independent cartridge springs arranged radially to uniformly distribute the load on the piston.
- Dual function main gasket. Piston seal: the gasket does not move but sits securely on the actuator cylinder instead of the piston. External seal: the gasket positioned above the threaded joint between the bonnet and cylinder ensures that the coupling is not stressed by the pressure inside the actuator.
- Easy installation in confined spaces: compressed air inlets with G 1/4" threaded adjustable connections to enable alignment with the piping. PPGR connections prevent any risk of corrosion.
- New valve body internal design. Substantially higher flow coefficient and lower pressure drops. The degree of efficiency reached has also enabled the size and weight of the valve to be reduced. Adjustment linearity: the internal profiles of the valve greatly improve its characteristic curve, allowing extremely sensitive and precise adjustment along the entire length of the shutter stroke.
- Joint system for solvent welding (PVC-U and PVC-C only), for welding (PP-H and PVDF only), for threading and flanging
- Optimised fluid dynamic design: maximum output flow rate thanks to the optimised efficiency of the fluid dynamics that characterise the new internal geometry of the body
- Internal operating components in metal totally isolated from the conveyed fluid and external environment
- Modularity of the range: only 2 hand wheels and 4 diaphragms and bonnet sizes for 7 different valve sizes
- Non-salient hand wheel, equipped with a graduated optical indicator and protected by a transparent PVC cap with sealing O-ring.
- Bonnet fastening screws in STAINLESS steel protected by PE plugs. Absence of metal parts exposed to the external environment to prevent any risk of corrosion
- New flanged bodies: the new bodies, characterised by a monolithic flanged structure, are available in PVC-U, PVC-C, PP-H and PVDF. This design, free of joints between the body and flanges, greatly reduces mechanical stress and increases system performance
- CDSA seal system (Circular Diaphragm Sealing Angle) with a uniform distribution of the shutter pressure on the sealing membrane offers the following advantages:
  - - Operating torque reduction.
  - - Reduced mechanical stress on all valve components (actuator, body and diaphragm).
  - - Low risk of the accumulation of deposits, contamination or damage to the diaphragm due to crystallisation.
  - - Easy to clean valve interior.