

TIM - Fitting for socket welding, Tee

90° Tee for socket welding, equal socket.

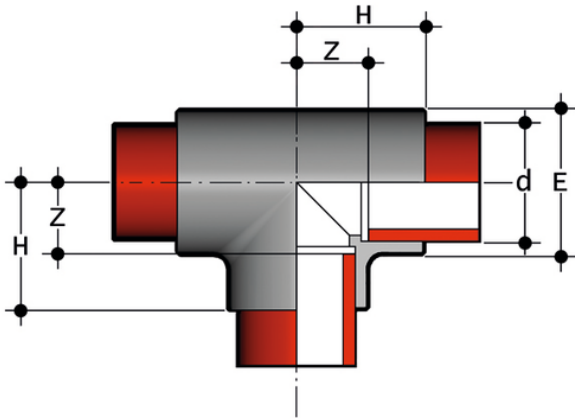

Reference	tooltiplmage	system	Category	family	d	DN	PN	E	H	Z	g
TIM020	-	PP-H system	Pressure Fittings	ISO-UNI Fittings Socket Welding	20	15	10	28	28	13	19
TIM025	-	PP-H system	Pressure Fittings	ISO-UNI Fittings Socket Welding	25	20	10	34	32	16	30
TIM032	-	PP-H system	Pressure Fittings	ISO-UNI Fittings Socket Welding	32	25	10	42	37	19	47
TIM040	-	PP-H system	Pressure Fittings	ISO-UNI Fittings Socket Welding	40	32	10	52	43	23	80
TIM050	-	PP-H system	Pressure Fittings	ISO-UNI Fittings Socket Welding	50	40	10	64	52	29	145
TIM063	-	PP-H system	Pressure Fittings	ISO-UNI Fittings Socket Welding	63	50	10	80	63	35	250
TIM075	-	PP-H system	Pressure Fittings	ISO-UNI Fittings Socket Welding	75	65	10	93	71	40	370
TIM090	-	PP-H system	Pressure Fittings	ISO-UNI Fittings Socket Welding	90	80	10	111	82	46	560
TIM110	-	PP-H system	Pressure Fittings	ISO-UNI Fittings Socket Welding	110	100	10	135	100	58	990