

DBS

Installation kit for tapping valves

Installation kit DBS

- To operate the DAV RED SNAP from the road cap downwards
- KlickFix (tool-free) with foam rubber
- Wrench size SW14 (14 mm)
- Telescopic bar:
 - Length fitting
 - Continuously adjustable (without tools)
- Self-supporting
- Corrosion free

Note:

The installation kit DBS is suitable for use with FRIALEN tapping valves DAV Classic and DAV RED SNAP.

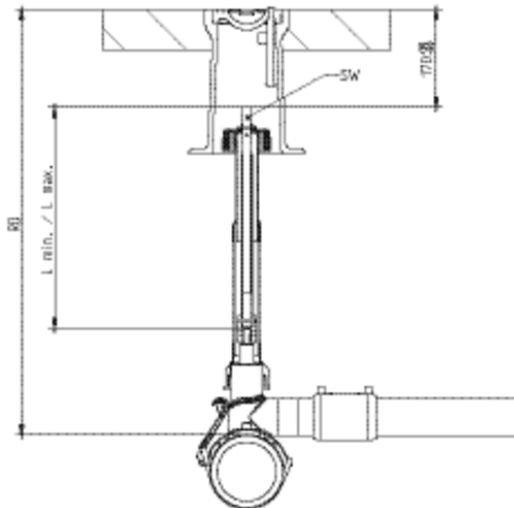

Reference	RD in m	BX	PU	l _{min}	l _{max}	SW	Weight kg
616998	0,45 - 0,7	1	42	260	370	14	1,740
616999	0,7 - 1,0	1	42	410	670	14	2,150
617000	0,9 - 1,3	1	42	525	980	14	2,650
617001	1,2 - 1,8	1	42	860	1570	14	3,600
617002	1,8 - 2,7	1	42	1560	2870	14	3,600
617003	2,6 - 3,5	1	42	1670	3910	14	4,500

Other lengths available on request.

The installation equipment DBS is suitable for use with FRIALEN Tapping Valves DAV and DAV RED SNAP.

DBS

Installation kit for tapping valves

Areas of Application

The telescopic installation kit DBS enables the house connection line to be shut off and reopened by the FRIALEN pressure tapping valve DAV RED SNAP via the surface box.

In addition to the „open“ and „shut off“ functions, subsequent tapping can also be carried out.

The installation set DBS is in its length range (RD = pipe covers) infinitely adjustable without tools, even when installed, and is self-supporting in every position.

Assembly Instructions

The installation kit DBS and the DAV RED SNAP form a perfectly matched unit.

Both components are connected via a 14mm square of the pressure tapping valve DAV RED SNAP. The KlickFix-System ensures pull-out safety.

The integrated locking function on the installation kit ensures a form-locked connection of the two components. An unintentional loosening is thus prevented (see Fig. below).

Good reasons for DBS installation kit for pressure tapping valves DAV RED SNAP:

- Easy and safe installation
- Installation set can be adjusted in the stated range (see table L_{min} and L_{max}) without the use of tools
- Self-supporting in all telescopic positions
- Safe from being pulled out
- Corrosion resistant
- The telescopic installation kit can be adjusted in place even if filled
- With the integrated locking function in the sleeve tube bell of the installation kit, a permanent and longitudinal force-fit connection with the DAV RED SNAP is ensured. This prevents unintentional release of the installation kit
- A foam rubber ring, which can optionally be used, in the sleeve tube bell ensures that no dirt can penetrate
- Compact construction → ideal and safe torque transmission onto the DAV RED SNAP
- Connection pins made of stainless steel
- Break-proof dome coupler
- Parts of the protective pipe are fully welded together
- The installation kit DBS is usable for FRIALEN pressure tapping valves DAV and DAV RED SNAP