



FE/CE - FE/CP DN 40÷200

PVC-U

ELECTRICALLY OR PNEUMATICALLY ACTUATED
BUTTERFLY VALVE



FE/CE – FE/CP

DN 40÷200

The FE is a butterfly valve for shutting off or regulating flow, specifically designed for water conveyance applications.

ELECTRICALLY OR PNEUMATICALLY ACTUATED BUTTERFLY VALVE

- Disk in PVC-U with through shaft
- **Zinc plated square section steel stem completely isolated from the fluid** complying with standard ISO 5211:
 - DN 40 ÷ 65: 11 mm
 - DN 80 ÷ 100: 14 mm
 - DN 125 ÷ 150: 17 mm
 - DN 200: 22 mm
- Can also be installed as an end line valve, bottom discharge valve or tank dump valve
- **Valve material compatibility** (PVC-U) with water conveyance, drinking water and other food substances according to **current regulations**
- Possibility of directly installing pneumatic and/or electric actuators with a standard drilling pattern according to standard ISO 5211 F05, F07, F10

Technical specifications - FE	
Construction	Bi-directional centric butterfly valve
Size range	DN 40 ÷ 200
Nominal pressure	DN 40 ÷ 50: PN16 with water at 20° C DN 65÷200: PN 10 with water at 20° C
Temperature range	0 °C ÷ 60 °C
Coupling standards	Flanging system: EN ISO 1452, EN ISO 15493, DIN 2501, ISO 7005-1, EN 1092-1, ASTM B16.5 Cl.150, JIS B2220
Reference standards	Construction criteria: EN ISO 16136, EN ISO 1452, EN ISO 15493 Test methods and requirements: ISO 9393 Actuator couplings: ISO 5211
Valve material	Body: PVC-U Disk: PVC-U Stem: Zinc plated carbon steel (C45). On request STAINLESS steel AISI 316
Seal material	Liner: EPDM, FKM
Control options	Pneumatic actuator, electric actuator

In addition to the manually actuated version, FE is also available in FE/ CE electrically actuated and FE/CP pneumatically actuated configurations.

FE/CD and FE/CP are constructed with actuators meeting current regulations and selected by FIP according to their quality and reliability requirements. The efficiency of these valves, tested according to the company's quality standards, is guaranteed by the expertise and know-how that FIP dedicates to manufacturing its products.

Technical specifications - Electric actuator	
Reference standards	Construction criteria: Electromagnetic compatibility EMC 2004/108/CE. Low voltage directive 2006/95/CE. Machinery directive 2006/42/CE. R.O.H.S. directive 2011/65/CE Coupling for valves: ISO 5211; DIN 3337
Actuator material	Plastic parts: PA6,6 30% and Nylon. Metallic parts: 304L stainless steel or steel + zinc plating (DN40-100); Aluminium + EPOXY paint (DN125-200)
Supply Voltage	12V DC* - 24V AC/DC - 90-240V AC - 400V three phase* *voltages available upon request
Temperature range	From -10 °C to +55 °C
Standard equipment	<ul style="list-style-type: none"> • Manual safety override • Visual position indicator • Two auxiliary limit switches (5A) adjustable FC1, FC2 • Torque limiter • Anti-condensation heating element (IP66-IP67) (DN125-200)
Accessories	<ul style="list-style-type: none"> • Positioner board 4-20 mA or 0-10V DC • Fail Safe unit • Anti-condensation heating element (DN40-100) • Feedback potentiometer 100 - 1000 - 5000 - 10000 Ohm • 4-20 mA position transmitter • Kit with additional pair of auxiliary limit switches
Special versions upon request	<ul style="list-style-type: none"> • CEI34 50% service • Protection class IP68 or ATEX II 2 GD EEx d IIB T6 • Different operating times
Electrical connection	<ul style="list-style-type: none"> • Power supply: connector DIN 43650 3P + GND (DN 40-100); cable gland ISO M20 (DN 125-200) • Limit switch: Cable gland ISO M20

Technical specifications - Pneumatic actuator	
Reference standards	Construction criteria: Machinery directive 2006/42/CE R.O.H.S. directive 2011/65/CE EN 15714-3 Coupling for valves: ISO 5211, DIN 3337 Compressed air connections: NAMUR VDI/VDE-3845 Top connections for accessories: NAMUR VDI/VDE-3845
Actuator material	Body: hard coat anodised extruded aluminium. IP67 Bonnet: polyester powder painted aluminium alloy Pinion: nickel-plated carbon steel Other materials available upon request
Control air pressure	From 5 to 8 bar. Pmax= 10 bar Reduced control pressure executions available upon request
Power supply	Dry or lubricated filtered compressed air. If using other fluids, contact the FIP service centre
Temperature range	From -20 °C to +80 °C
Accessories	<ul style="list-style-type: none"> • Optical position indicator • LSQT electromechanical and PNP inductive limit switch boxes (Namur upon request) • Electric-pneumatic positioner 4-20 mA • 3-5/2 way pilot solenoid valves
Available options	Body and bonnet with PTFE, AISI 316 or AISI 316 coating with mirror polishing. 304 or 316 stainless steel pinion.

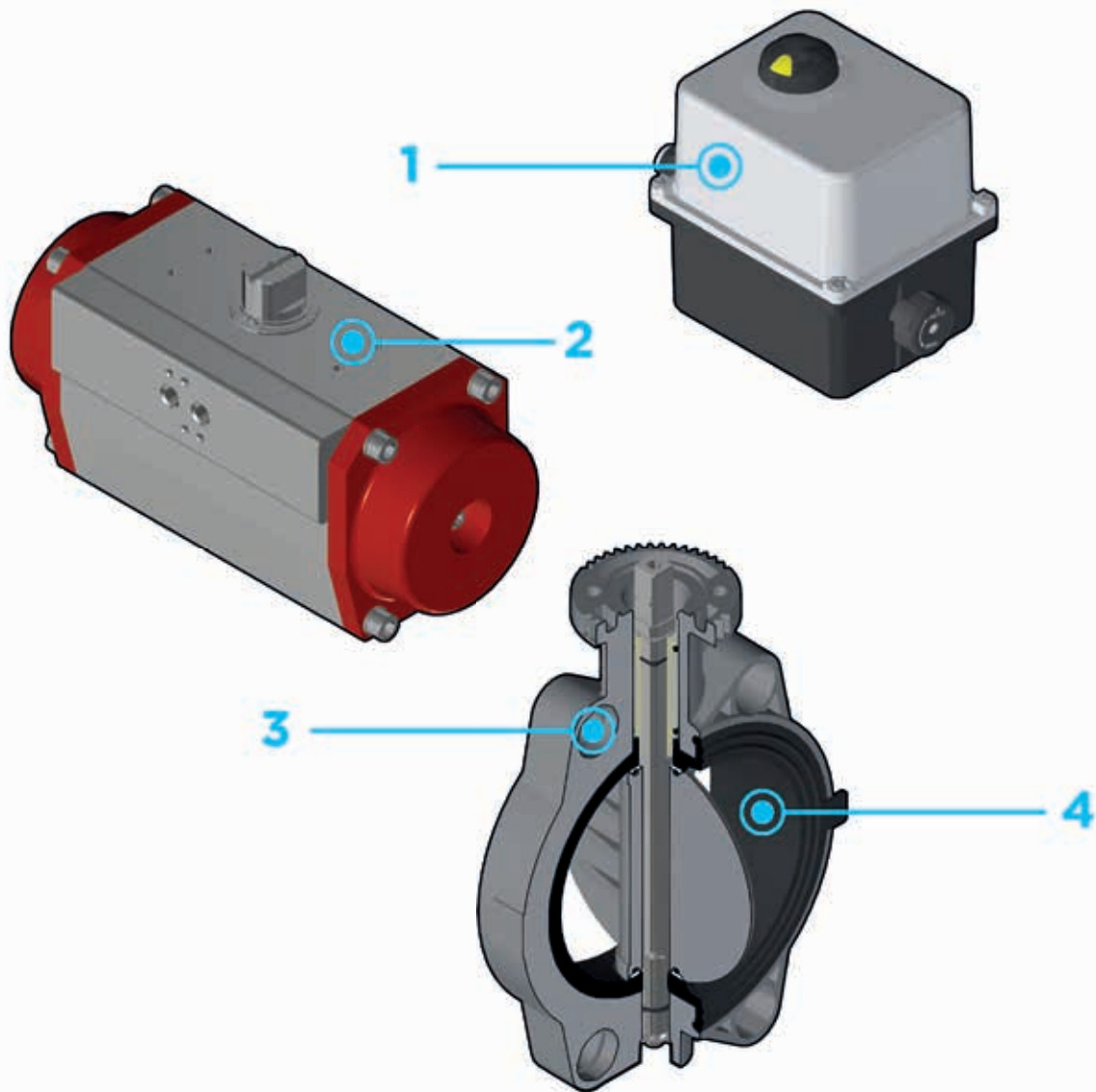

1 Electric actuator constructed according to FIP specifications; with plastic shell and standard emergency override. Available with voltages from 12 to 240V.

2 Rack & pinion type pneumatic actuator constructed according to FIP specifications: fully protected

against weather corrosion available in double-acting (DA) or simple-acting normally closed (NC) or normally open (NO) versions.

3 **Drilling pattern with oval slots** that allow coupling to flanges according to numerous international standards.

4 **Interchangeable liner** with the dual function of forming a hydraulic seal and isolating the body from the fluid.

TECHNICAL DATA

PRESSURE VARIATION ACCORDING TO TEMPERATURE

PVC-U BODY

For water and non-hazardous fluids with regard to which the material is classified as CHEMICALLY RESISTANT. In other cases, a reduction of the nominal pressure PN is required (25 years with safety factor).

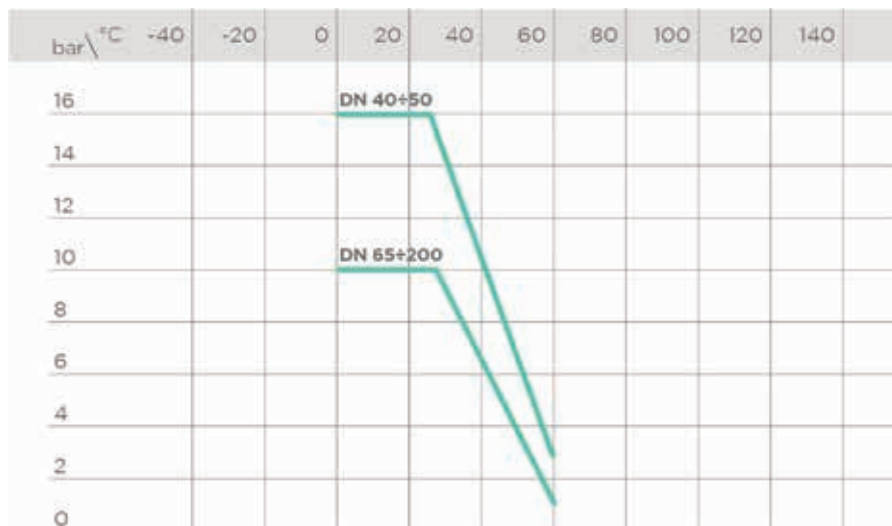

PRESSURE DROP GRAPH

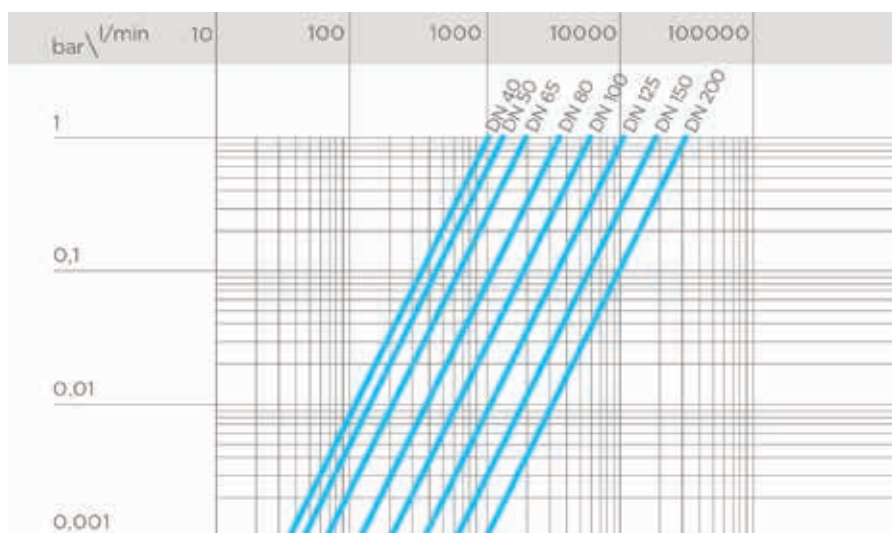

K_v100 FLOW COEFFICIENT

The K_v100 flow coefficient is the Q flow of litres per minute of water at a temperature of 20°C that will generate Δp= 1 bar pressure drop at a certain valve position.

The K_v100 values shown in the table are calculated with the valve completely open.

DN	40	50	65	80	100	125	150	200
Kv100 l/min	1000	1285	1700	3550	5900	9850	18700	30500

RELATIVE FLOW COEFFICIENT GRAPH

The relative flow coefficient is the flow rate through the valve as a function of the degree of valve opening.

X axis: Percentage opening of the disk

Y axis: Relative flow coefficient

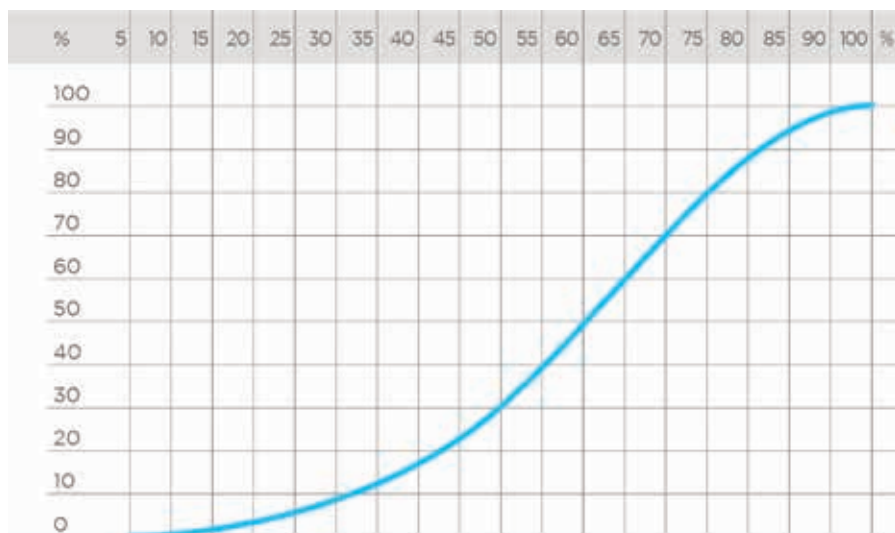

ELECTRIC ACTUATOR DATA

DN40÷65 FUNCTIONAL CHARACTERISTICS

Characteristics	DC	AC/DC	AC
Power supply	*12V	24V	90÷240V
Power	15W	15W	15W
Max operating time	11 s	12 s	13 s
IEC34 service	50%	30%	30%
Protection class	IP66	IP65	IP65
Frequency	-	50/60 Hz	50/60 Hz

DN80÷100

Characteristics	DC	AC/DC	AC
Power supply	*12V	24V	90÷240V
Power	45W	45W	45W
Max operating time	12 s	13 s	15 s
IEC34 service	50%	30%	30%
Protection class	IP66	IP65	IP65
Frequency	-	50/60 Hz	50/60 Hz

DN125÷150

Characteristics	AC/DC	AC
Power supply	24V	90÷240V
Power	85W	85W
Max operating time	30 s	30 s
IEC34 service	50%	50%
Protection class	IP67	IP67
Frequency	50/60 Hz	50/60 Hz

DN200

Characteristics	AC/DC	AC
Power supply	24V	90÷240V
Power	85W	85W
Max operating time	50 s	50 s
IEC34 service	50%	50%
Protection class	IP67	IP67
Frequency	50/60 Hz	50/60 Hz

DN 40-100 POWER CONNECTION DIAGRAM

- 1 Shared
- 2 Open
- 3 Closed

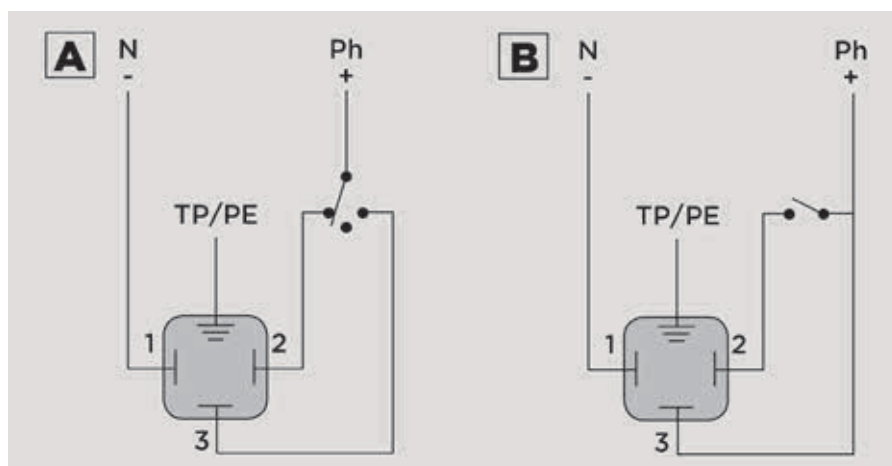

DN 125-200 POWER CONNECTION DIAGRAM

- 1 Shared
- 2 Open
- 3 Closed

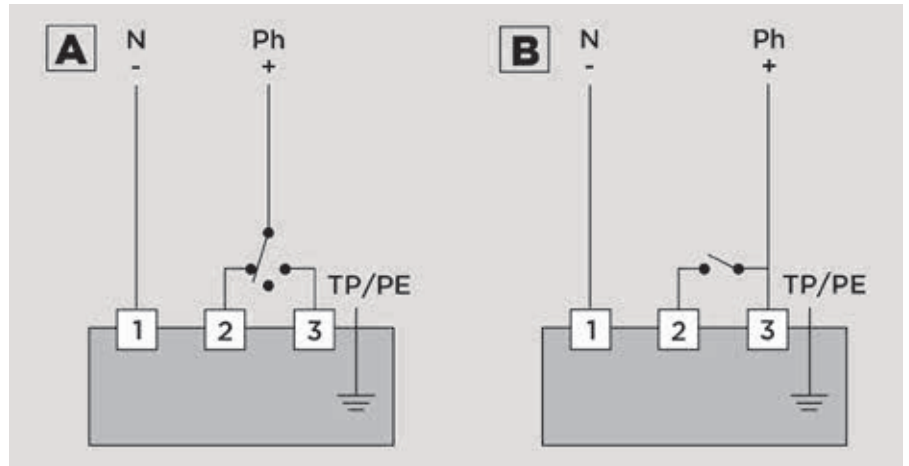

DN40-200 AUXILIARY LIMIT SWITCH CONNECTION DIAGRAM

- FC1 Open auxiliary limit switch
- FC2 Close auxiliary limit switch

- 4 Shared FC1
- 5 Open FC1
- 6 Shared FC2
- 7 Open FC2
- 8 Close FC1
- 9 Close FC2

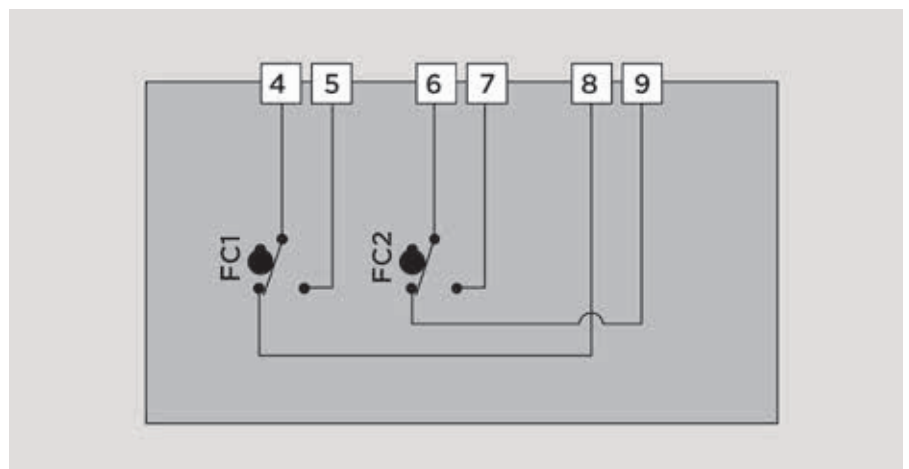

PNEUMATIC ACTUATOR DATA

FUNCTIONAL CHARACTERISTICS

Function type	double-acting	Normally closed (NC)	Normally Open (NO)
Valve opening	air	air	spring
Valve closing	air	spring	air

ACTUATOR CAPACITY

L: litre, equivalent to 10^{-3} m^3

Air consumption in normal litres (or normal cubic metres) per operating cycle can be calculated by correcting according to operating conditions such as control air pressure.

DN	40	50	65	80	100	125	150	200
DA	0.45 L	0.45 L	0.45 L	0.61 L	0.98 L	0.98 L	1.8 L	2.8 L
SA (NC-NO)	0.18 L	0.244 L	0.244 L	0.302 L	0.72 L	1.12 L	1.12 L	3.2 L

COMPRESSED AIR CONNECTIONS

Function type	Double-acting (DA)	Normally closed (NC)	Normally Open (NO)
Valve opening	Inlet A	Inlet A	-
Valve closing	Inlet B	-	Inlet A

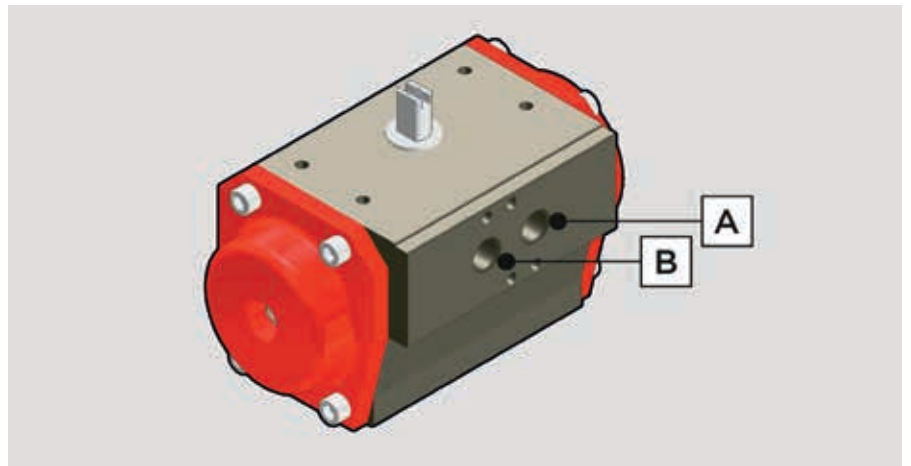

DIMENSIONS

FE/CE DN 40÷200 PVC-U

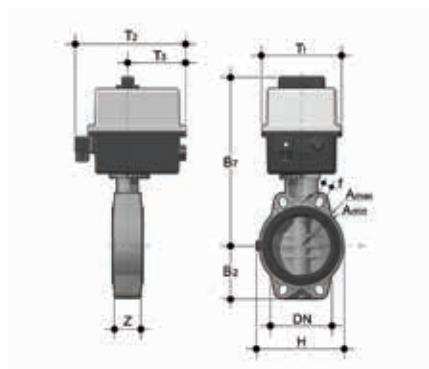

FEOV/CE 90-240V AC DN 40-100

Butterfly valve with multi-volt electric actuator 90-240 V AC 50-60 Hz

d	DN	PN	B ₂	H	Z	A _{min}	A _{max}	f	U	B ₇	T ₁	T ₂	T ₃	g	EPDM Code	FKM Code
50-1 1/2"	40	16	60	132	33	93.5	109	19	4	253	92	187	91	2074	FEOVEM050E	FEOVEM050F
63-2"	50	16	70	147	43	108	124	19	4	259	92	187	91	2254	FEOVEM063E	FEOVEM063F
75-2 1/2"	65	10	80	165	46	128	144	19	4	266	92	187	91	2480	FEOVEM075E	FEOVEM075F
90-3"	80	10	90	130	49	145	159	19	4	308	128	202	95.5	4000	FEOVEM090E	FEOVEM090F
110-4"	100	10	105	150	56	165	190	19	4	322	128	202	95.5	4350	FEOVEM110E	FEOVEM110F

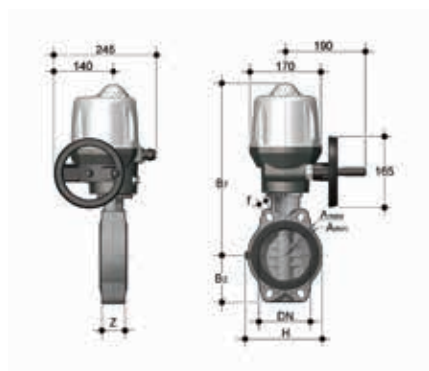

FEOV/CE 90-240V AC DN 125-150

Butterfly valve with multi-volt electric actuator 90-240 V AC 50-60 Hz

d	DN	PN	B ₂	H	Z	A _{min}	A _{max}	f	U	B ₇	g	EPDM Code	FKM Code
*125/140-5"	125	10	121	185	64	204	215	23	4	425	8100	FEOVEM140E	FEOVEM140F
160-6"	150	10	132	210	70	230	242	23	4	438	8800	FEOVEM160E	FEOVEM160F

*FEOV d140 with special adapter collars d125

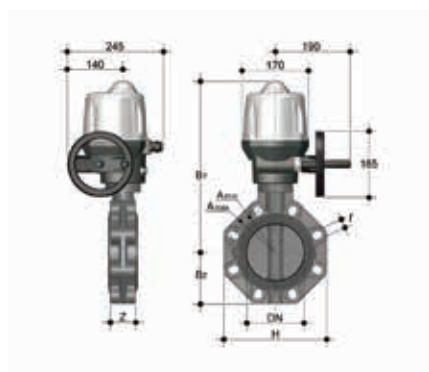

FEOV/CE 90-240V AC DN 200

Butterfly valve with multi-volt electric actuator 90-240 V AC 50-60 Hz

d	DN	PN	B ₂	H	Z	A _{min}	A _{max}	f	U	B ₇	g	EPDM Code	FKM Code
**200/225-8"	200	10	161	325	71	280	298	23	8	485	11560	FEOVEM225E	FEOVEM225F

**FEOV d225 with special adapter collars d200

DIMENSIONS

FE/CE DN 40÷200 PVC-U

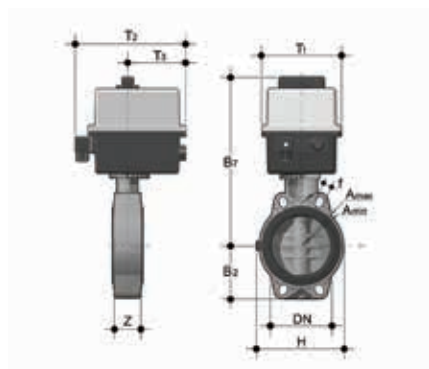

FEOV/CE 24V AC/DC DN 40-100

Butterfly valve with electric actuator 24 V AC/DC

d	DN	PN	B ₂	H	Z	A _{min}	A _{max}	f	U	B ₇	T ₁	T ₂	T ₃	g	EPDM Code	FKM Code
50-1 1/2"	40	16	60	132	33	93.5	109	19	4	253	92	187	91	2074	FEOVEL050E	FEOVEL050F
63-2"	50	16	70	147	43	108	124	19	4	259	92	187	91	2254	FEOVEL063E	FEOVEL063F
75-2 1/2"	65	10	80	165	46	128	144	19	4	266	92	187	91	2480	FEOVEL075E	FEOVEL075F
90-3"	80	10	90	130	49	145	159	19	4	308	128	202	95.5	4000	FEOVEL090E	FEOVEL090F
110-4"	100	10	105	150	56	165	190	19	4	322	128	202	95.5	4350	FEOVEL110E	FEOVEL110F



FEOV/CE 24V AC/DC DN 125-150

Butterfly valve with electric actuator 24 V AC/DC

d	DN	PN	B ₂	H	Z	A _{min}	A _{max}	f	U	B ₇	g	EPDM Code	FKM Code
*125/140-5"	125	10	121	185	64	204	215	23	4	425	8100	FEOVEL140E	FEOVEL140F
160-6"	150	10	132	210	70	230	242	23	4	438	8800	FEOVEL160E	FEOVEL160F

*FEOV d140 with special adapter collars d125

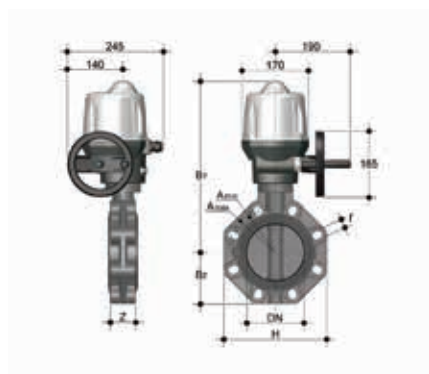

FEOV/CE 24V AC/DC DN 200

Butterfly valve with electric actuator 24 V AC/DC

d	DN	PN	B ₂	H	Z	A _{min}	A _{max}	f	U	B ₇	g	EPDM Code	FKM Code
**200/225-8"	200	10	161	325	71	280	298	23	8	485	11560	FEOVEL225E	FEOVEL225F

*FEOV d225 with special adapter collars d200

DIMENSIONS

FE/CP DN 40÷200 PVC-U

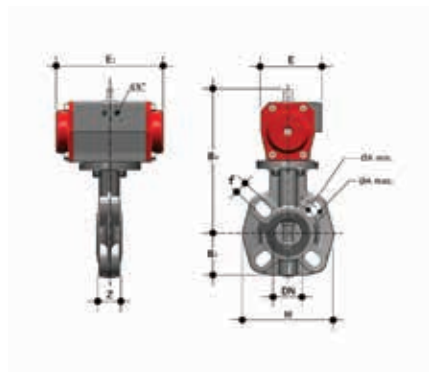

FEOV/CP DA DN 40-65

Butterfly valve with pneumatic actuator, Double-Acting function

d	DN	PN	B ₂	H	Z	A _{min}	A _{max}	f	U	B ₄	E	E ₁	g	EPDM Code	FKM Code
50-1 1/2"	40	16	60	132	33	93.5	109	19	4	209	86	155	2170	FEOVDA050E	FEOVDA050F
63-2"	50	16	70	147	43	108	124	19	4	215	86	155	2350	FEOVDA063E	FEOVDA063F
75-2 1/2"	65	10	80	165	46	128	144	19	4	222	86	155	2580	FEOVDA075E	FEOVDA075F

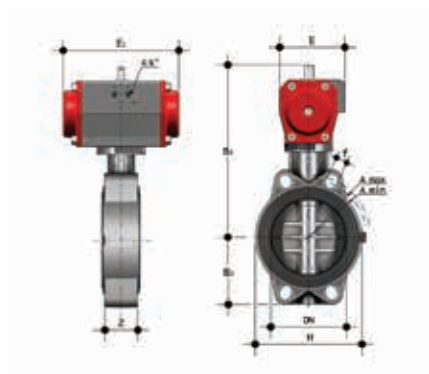

FEOV/CP DA DN 80-150

Butterfly valve with pneumatic actuator, Double-Acting function

d	DN	PN	B ₂	H	Z	A _{min}	A _{max}	f	U	B ₄	E	E ₁	g	EPDM Code	FKM Code
90-3"	80	10	90	130	49	145	159	19	4	253	94	210	4100	FEOVDA090E	FEOVDA090F
110-4"	100	10	105	150	56	165	190	19	4	277	104	228	5750	FEOVDA110E	FEOVDA110F
*125/140-5"	125	10	121	185	64	204	215	23	4	297	104	228	6700	FEOVDA140E	FEOVDA140F
160-6"	150	10	132	210	70	230	242	23	4	325	120	280	9000	FEOVDA160E	FEOVDA160F

*FEOV d140 with special adapter collars d125

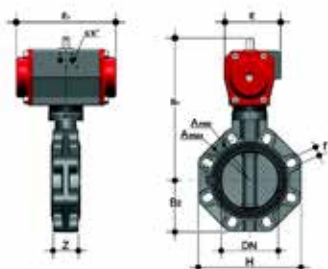

FEOV/CP DA DN 200

Butterfly valve with pneumatic actuator, Double-Acting function

d	DN	PN	B ₂	H	Z	A _{min}	A _{max}	f	U	B ₄	E	E ₁	g	EPDM Code	FKM Code
**200/225-8"	200	10	161	325	71	280	298	23	8	399	134	310	15150	FEOVDA225E	FEOVDA225F

* FEOV d225 with special adapter collars d200

DIMENSIONS

FE/CP DN 40÷200 PVC-U

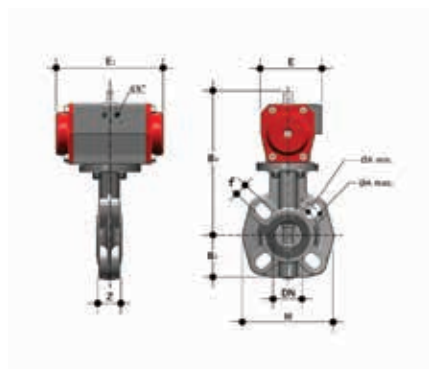

FE/CP NC DN 40-65

Butterfly valve with pneumatic actuator, Normally Closed function

d	DN	PN	B ₂	H	Z	A _{min}	A _{max}	f	U	B ₄	E	E ₁	g	EPDM Code	FKM Code
50-1 1/2"	40	16	60	132	33	93.5	109	19	4	209	86	155	2370	FEOVNC050E	FEOVNC050F
63-2"	50	16	70	147	43	108	124	19	4	232	94	210	4120	FEOVNC063E	FEOVNC063F
75-2 1/2"	65	10	80	165	46	128	144	19	4	239	94	210	4380	FEOVNC075E	FEOVNC075F

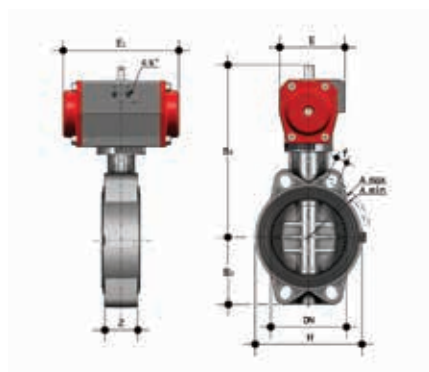

FE/CP NC DN 80-150

Butterfly valve with pneumatic actuator, Normally Closed function

d	DN	PN	B ₂	H	Z	A _{min}	A _{max}	f	U	B ₄	E	E ₁	g	EPDM Code	FKM Code
90-3"	80	10	90	130	49	145	159	19	4	263	104	228	6000	FEOVNC090E	FEOVNC090F
110-4"	100	10	105	150	56	165	190	19	4	292	120	280	8350	FEOVNC110E	FEOVNC110F
*125/140-5"	125	10	121	185	64	204	215	23	4	339	134	310	12800	FEOVNC140E	FEOVNC140F
160-6"	150	10	132	210	70	230	242	23	4	352	134	310	13500	FEOVNC160E	FEOVNC160F

*FEOV d140 with special adapter collars d125

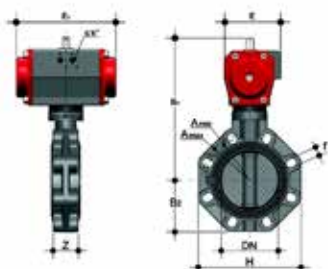

FE/CP NC DN 200

Butterfly valve with pneumatic actuator, Normally Closed function

d	DN	PN	B ₂	H	Z	A _{min}	A _{max}	f	U	B ₄	E	E ₁	g	EPDM Code	FKM Code
**200/225-8"	200	10	161	325	71	280	298	23	8	473	176	462	35250	FEOVNC225E	FEOVNC225F

* FEOV d225 with special adapter collars d200

DIMENSIONS

FE/CP DN 40÷200 PVC-U

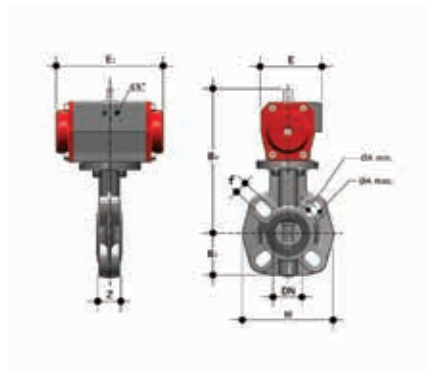

FEOV/CP NO DN 40-65

Butterfly valve with pneumatic actuator, Normally Open function

d	DN	PN	B ₂	H	Z	A _{min}	A _{max}	f	U	B ₄	E	E ₁	g	EPDM Code	FKM Code
50-1 1/2"	40	16	60	132	33	93.5	109	19	4	209	86	155	2370	FEOVNO050E	FEOVNO050F
63-2"	50	16	70	147	43	108	124	19	4	232	94	210	4120	FEOVNO063E	FEOVNO063F
75-2 1/2"	65	10	80	165	46	128	144	19	4	239	94	210	4380	FEOVNO075E	FEOVNO075F

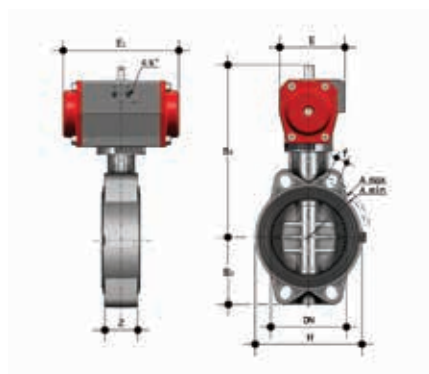

FEOV/CP NO DN 80-150

Butterfly valve with pneumatic actuator, Normally Open function

d	DN	PN	B ₂	H	Z	A _{min}	A _{max}	f	U	B ₄	E	E ₁	g	EPDM Code	FKM Code
90-3"	80	10	90	130	49	145	159	19	4	263	104	228	6000	FEOVNO090E	FEOVNO090F
110-4"	100	10	105	150	56	165	190	19	4	292	120	280	8350	FEOVNO110E	FEOVNO110F
*125/140-5"	125	10	121	185	64	204	215	23	4	339	134	310	12800	FEOVNO140E	FEOVNO140F
160-6"	150	10	132	210	70	230	242	23	4	352	134	310	13500	FEOVNO160E	FEOVNO160F

*FEOV d140 with special adapter collars d125

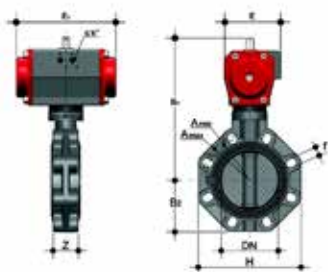

FEOV/CP NO DN 200

Butterfly valve with pneumatic actuator, Normally Open function

d	DN	PN	B ₂	H	Z	A _{min}	A _{max}	f	U	B ₄	E	E ₁	g	EPDM Code	FKM Code
**200/225-8"	200	10	161	325	71	280	298	23	8	473	176	462	35250	FEOVNO225E	FEOVNO225F

* FEOV d225 with special adapter collars d200

COMPONENTS

EXPLODED VIEW DN 40÷65

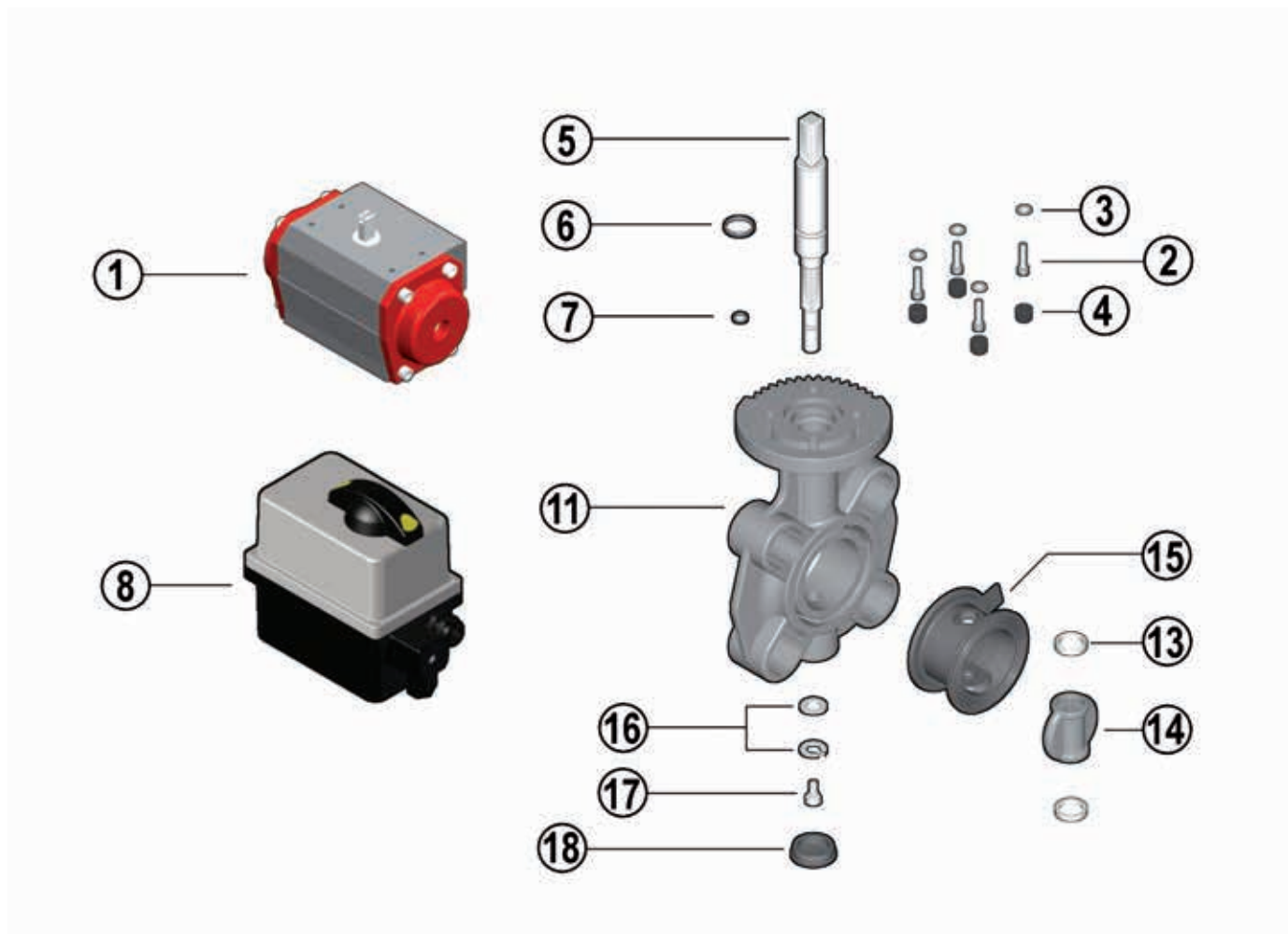

- 1** Pneumatic actuator (Finished aluminium - 1)
- 8** Electric actuator (PA6-Nylon - 1)
- 2** Screw (STAINLESS steel - 4)*
- 3** Washer (STAINLESS steel - 4)*
- 4** Protection plug (PE - 4)*

- 5** Stem (Zinc plated steel - 1)*
- 6** Stem O-Ring (EPDM or FKM - 1)*
- 7** Stem O-Ring (EPDM or FKM - 1)*
- 11** Body (PVC-U - 1)
- 13** Anti-friction ring (PTFE - 2)*
- 14** Disk (PVC-U - 1)*

- 15** Primary gasket (EPDM or FKM - 1)*
- 16** Washer (Steel- 1)
- 17** Screw (STAINLESS steel - 1)
- 18** Protection plug (PE - 1)

* Spare parts

The material the component is made of and the quantity supplied are shown in brackets

EXPLODED VIEW DN 80÷200

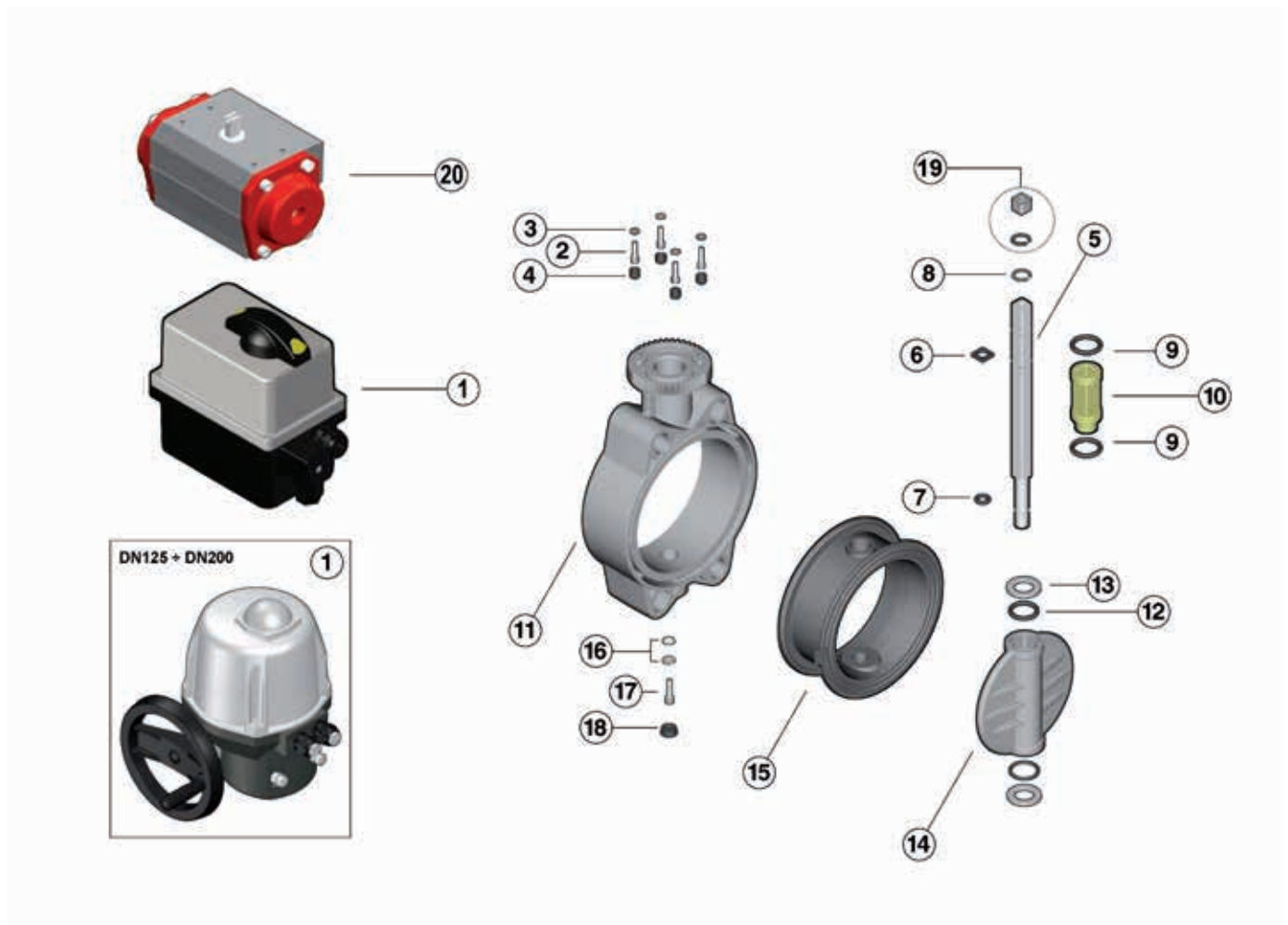

- | | | | | | |
|-----------|--|-----------|-----------------------------------|-----------|--|
| 1 | Electric actuator (PA6-Nylon** - 1)* | 7 | Stem O-Ring (EPDM or FKM - 1)* | 15 | Primary gasket (EPDM or FKM - 1)* |
| 20 | Pneumatic actuator (Finished aluminium - 1)* | 8 | Seeger ring (STAINLESS steel - 2) | 16 | Washer (Acciaio INOX - 4) |
| 2 | Screw (STAINLESS steel - 4)* | 9 | Bush O-Ring (EPDM or FKM - 2)* | 17 | Screw (STAINLESS steel - 4) |
| 3 | Washer (STAINLESS steel - 4)* | 10 | Bush (Nylon - 1) | 18 | Protection plug (PE - 1) |
| 4 | Protection plug (PE - 4)* | 11 | Body (PVC-U - 1) | 19 | Square reduction (STAINLESS steel - 1) |
| 5 | Stem (Zinc plated steel - 1)* | 12 | Disk O-Ring (EPDM or FKM - 2)* | | |
| 6 | Stem O-Ring (EPDM or FKM - 1)* | 13 | Anti-friction ring (PTFE - 2)* | | |
| | | 14 | Disk (PVC-U - 1)* | | |

* Spare parts

**DN125÷200: PA6-Nylon + aluminium

The material the component is made of and the quantity supplied are shown in brackets

DISASSEMBLY

- 1) Isolate the valve from the line (release the pressure and empty the pipeline).
- 2) Disconnect the actuator from the compressed air supply and/or power mains.
- 3) Remove the protection plug (4) and screws (2) with the washers (3).
- 4) Remove the actuator (1/20).
- 5) Remove the protection plug (18) and screw (17) with the washer (16).
- 6) Extract the stem (5) and disk (14).
- 7) Remove the anti-friction rings (13) and seals (12).
- 8) Remove the seal (15) from the body (11).
- 9) Remove the Seeger ring (8) and guide bush (10).
- 10) Remove seals (6) and (7).

ASSEMBLY

- 1) Place the liner (15) on the body (11).
- 2) Insert seals (6 and 7) on the stem (5).
- 3) Insert the gaskets (9) on the guide bush (10) and the bush on the stem (4). Lock the bush using the Seeger ring (8).
- 4) Position the seals (12) and then the anti-friction rings (13) on the disk (14) and the disk inside the body, after having lubricated the seal (15).
- 5) Insert the through stem (5) in the body (11) and disk (14).
- 6) Tighten screw (17) with washer (16) and insert the protection plug (18).
- 7) Position the handle (1/20) on the stem.
- 8) Tighten screws (2) with washers (3) and insert the protection plugs (4).
- 9) Reconnect the actuator to the pneumatic and/or power supplies.



All operations on equipment under pressure or containing compressed springs must be carried out under safe conditions for the operator.

Note: during mounting operations, it is advisable to lubricate the rubber seals. Mineral oils are not recommended for this task as they react aggressively with EPDM rubber.

INSTALLATION

JOINTS

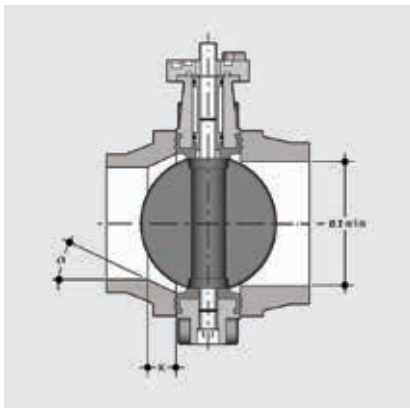

Before proceeding with the installation of the stubs, check that the bore of the fittings has sufficient clearance to allow the valve disk to open correctly. Also check the maximum coupling distance for the liner. Before proceeding with the installation of the FE valve, check that the bore of the stubs allows the correct opening of the disk.

DN	l min.
40	25
50	28
65	47
80	64
100	84
125	108
150	134
200	187

To install on PVC-U collars, check the valve-collar-flange couplings in the following table.

d	DN	50	63	75	90	110	125	140	160	200	225
		40	50	65	80	100	100	125	150	200	200
50	40	■									
63	50		■								
75	65			■							
90	80				■						
110	100					■					
140	125						■				
160	150							■			
225	200									■	**

Stub with female end for solvent welding according to EN ISO 1452 and DIN 8063-4

* With special stub d125 DN125 for FE d140 DN125 and flange d140 DN125

** With special stub d200 DN 200 for FE d225 DN 200 and flange d225 DN 200

For the installation of PP-PE stubs, for butt welding a short spigot or electrofusion/ butt welding a long spigot, check the valve-stub-flange couplings and the K - a chamfer dimensions where necessary according to the different SDRs in the following table.

	d	50	63	75	90	110	125	140	160	180	200	225	250	280	315
	DN	40	50	65	80	100	100	125	150	150	200	200	250	250	300
FE	50														
	63														
	75														
	90														
	110														
	140														
	160														
	225														
SDR	17/17,6										k=26,5 a=20°		k=15,7 a=25°		k=13,3 a=25°
	11								k=35 a=20°		k=35 a=25°	k=40 a=15°	k=32,5 a=25°	k=35 a=25°	k=34,5 a=25°
	7,4				k=10 a=35°	k=15 a=35°		k=20 a=30°	k=35 a=20°	k=15 a=35°	k=40 a=20°	k=35 a=30°	k=55 a=30°	k=35 a=30°	k=65 a=30°

Short/long spigot stubs according to EN ISO 15494 and DIN 16962/16963 and flange

POSITIONING THE VALVE

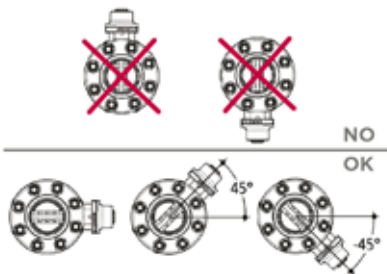

1) Position the valve between two flanged stubs, taking care to respect the installation tolerances Z. It is advisable to always install the valve with the disk partially closed (it must not exit the body) and avoid any misalignment of the flanges, as this may cause leaks.

2) The valve is two-way and can be installed in any position. It can also be installed at end line or tank.

3) Where possible comply with the following requirements:

- Conveying dirty fluids: position the valve with the stem inclined at an angle of 45° to the pipe support plane.
- Conveying fluids with sediment: position the valve with the stem parallel to the pipe support plane.
- Conveying clean fluids: position the valve with the stem perpendicular to the pipe support plane.

TIGHTENING THE STUD-BOLTS

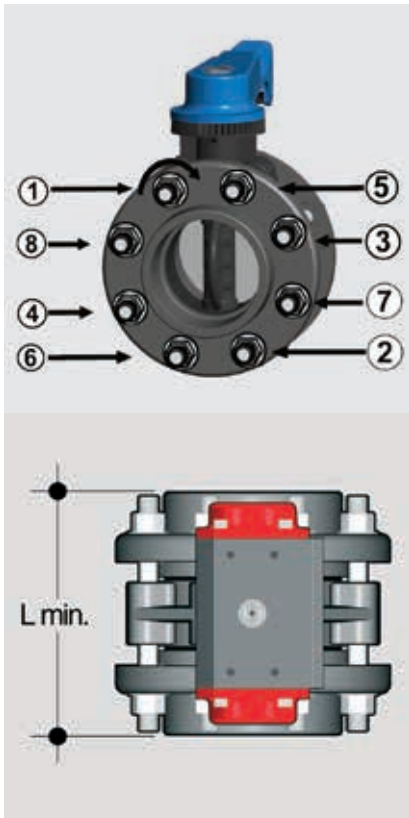

Before tightening the stud-bolts, it is advisable to open the disk in order to prevent damage to the seal. Tighten the stud-bolts in a uniform manner, in the order indicated in the figure, to the nominal operating torque value indicated in the table. The stud-bolts do not need to be excessively tightened in order to produce a perfect hydraulic seal.

DN	L min.	*Nm
40	M16 x150	9
50	M16 x150	12
65	M16 x170	15
80	M16 x180	18
100	M16 x180	20
125	M16 x210	35
150	M20 x 240	40
200	M20 x 260	55

* Tightening torques for nuts and bolts on couplings with backing rings.

Values required to obtain the hydraulic test seal (1.5xPN at 20°C) (new or lubricated nuts and bolts)

JIS FLANGED OPTIONS

FE is suited for wafer flanged installation in JIS K10 standard in DN40 (1 1/2") - DN150 (6") range and in JIS K5 in DN40 (1 1/2") - DN200 (8") range.

WARNINGS

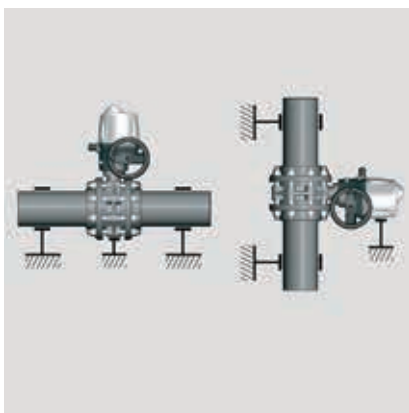

Make sure that the valves installed on the system are suitably supported for their weight.

Always avoid sudden manoeuvres and protect the valve from accidental operations. To this end, it is advisable to install a reduction gear, available on request.