



DKD/CP DN 15÷65

PVC-U

DIRECT ACTION PNEUMATICALLY ACTUATED
DIAPHRAGM VALVE



DKD/CP DN 15÷65

The DKD/CP diaphragm valve is particularly suited to shut off extremely dirty and/or high viscosity fluids. The new internal geometry of the body optimises fluid dynamic efficiency by increasing the flow rate. The DKP/CP is extremely compact and very light.

DIRECT ACTION PNEUMATICALLY ACTUATED DIAPHRAGM VALVE

- Connection system using solvent welded and threaded joints
- **Optimised fluid dynamic design:** maximum output flow rate thanks to the optimised efficiency of the fluid dynamics that characterise the new internal geometry of the body
- In the Standard version, equipped with textile fibre reinforced diaphragm
- Bonnet fastening screws in STAINLESS steel protected against the external environment by PE plugs
- Easy to clean valve interior
- Low risk of the accumulation of deposits, contamination or damage to the diaphragm due to crystallisation
- Easy to replace diaphragm seal.

| Technical specifications - DKD | |
|---------------------------------|--|
| Construction | Direct action pneumatically actuated diaphragm valve with body at maximized flow rate |
| Size range | DN 15 ÷ 65 |
| Nominal pressure | PN 8 with water at 20° C |
| Temperature range | 0 °C ÷ 60 °C |
| PVC-U coupling standards | Solvent welding: EN ISO 1452, EN ISO 15493, BS 4346-1, DIN 8063. Can be coupled to pipes according to EN ISO 1452, DIN 8062 Thread: ISO 228-1, DIN 2999 |
| Reference standards | Construction criteria: EN ISO 16138, EN ISO 1452, EN ISO 15493 Test methods and requirements: ISO 9393 PVC-U installation criteria: DVS 2204, DVS 2221, UNI 11242 |
| Valve material | PVC-U |
| Seal material | EPDM On request NBR |
| Control options | Pneumatic actuator |

The valve comprises three elements: body, diaphragm and sealing bonnet. Due to the action of the compressed air in the bonnet, the diaphragm is pressed against the body saddle interrupting the flow. This simplified operating principle and the lower number of components guarantees high reliability and durability.

| Technical specifications - actuator | |
|---|---|
| Construction | Direct action pneumatic piston actuator (NO) |
| Actuator material | Body: PP-GR |
| Control air pressure | Maximum: 10 bar |
| Differential air control pressure compared to conveyed fluid to obtain valve opening | 0.5 - 1.5 bar |
| Power supply | Neutral and clean fluid, free from mineral based lubricants, which are aggressive on EPDM rubber. If using other fluids, contact the FIP service centre |
| Control fluid temperature | Max 50 °C |
| Temperature range | -20 °C ÷ 50 °C |
| Accessories | • Pilot solenoid valves 3/2 ways for manifold mounting |

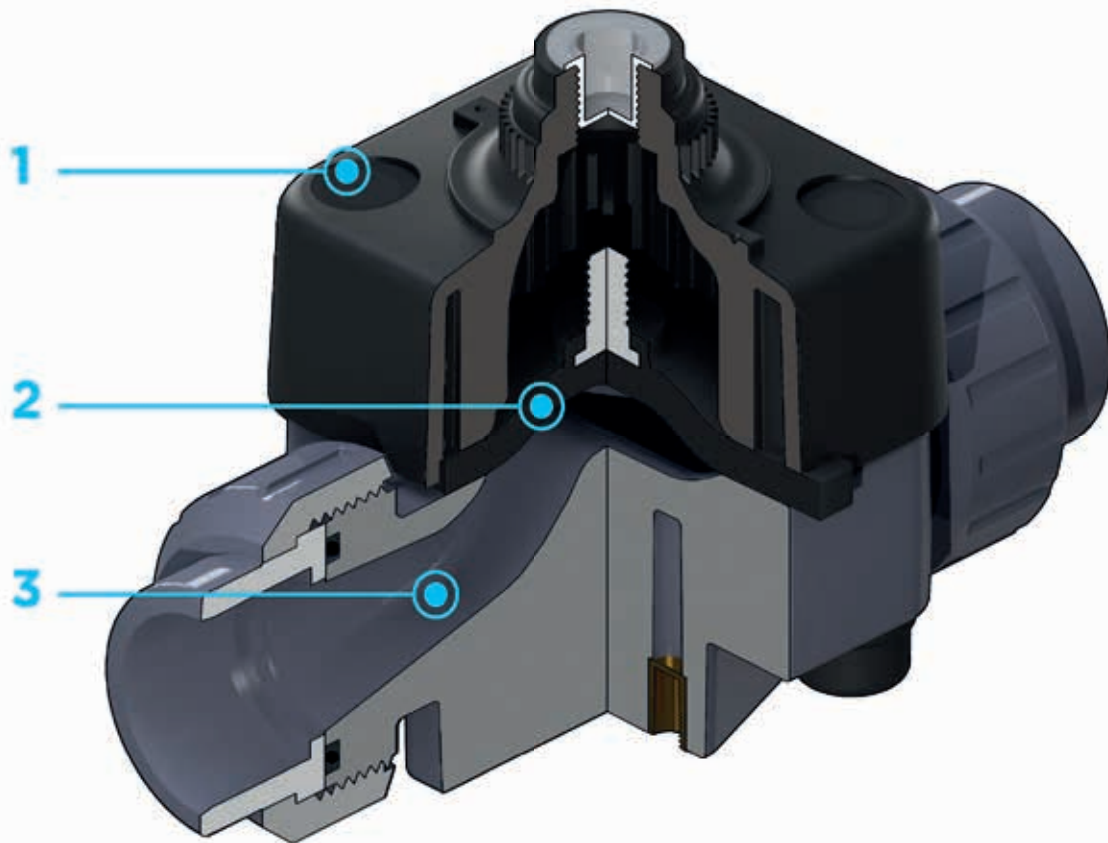

1 **PP-GR sealing bonnet** marked by **high construction strength**. The absence of metal parts exposed to the external environment prevents any risk of corrosion.

2 The special **sealing diaphragm** reinforced with textile fibres allows longer operation to be reached without showing any signs of wear.

3 **New valve body internal design**. **Substantially higher flow coefficient** and lower pressure drops. The degree of efficiency reached has also enabled the **size and weight of the valve to be reduced**.

TECHNICAL DATA

PRESSURE VARIATION ACCORDING TO TEMPERATURE

For water and non-hazardous fluids with regard to which the material is classified as CHEMICALLY RESISTANT. In other cases, a reduction of the nominal pressure PN is required (25 years with safety factor).



PRESSURE DROP GRAPH

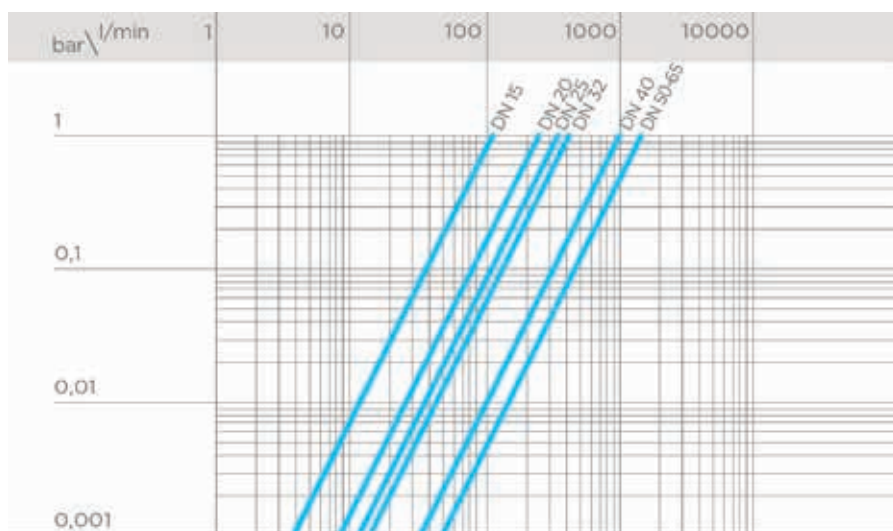

K_v100 FLOW COEFFICIENT

The K_v100 flow coefficient is the Q flow of litres per minute of water at a temperature of 20°C that will generate Δp= 1 bar pressure drop at a certain valve position.

The K_v100 values shown in the table are calculated with the valve completely open.

| DN | 15 | 20 | 25 | 32 | 40 | 50 | 65 |
|--------------------------|-----|-----|-----|-----|------|------|------|
| K _v 100 l/min | 112 | 261 | 445 | 550 | 1087 | 1648 | 1600 |

CONTROL PRESSURE ACCORDING TO WORKING PRESSURE

Minimum control pressure (Y axis) according to working pressure (X axis)

Note: to permit total valve opening, the in-line fluid working pressure must be at least 1.2 bar in DN50 and DN65 versions.

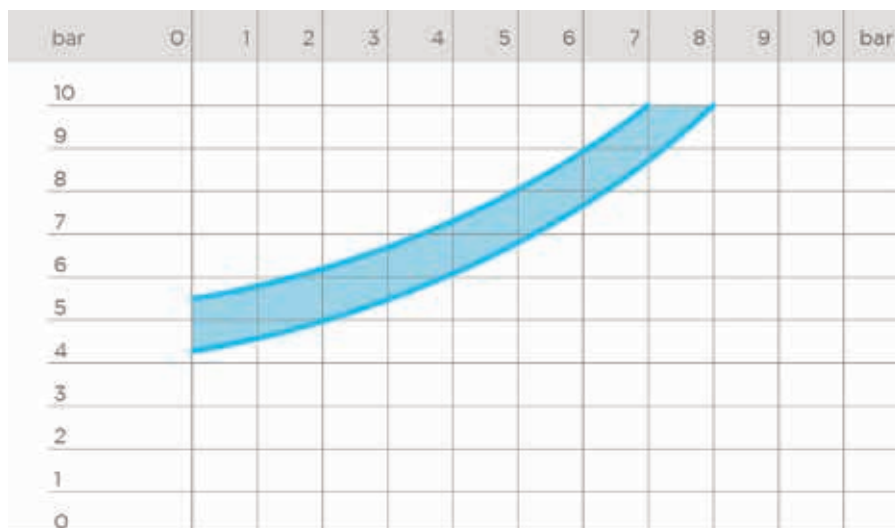

PNEUMATIC ACTUATOR DATA

FUNCTIONAL CHARACTERISTICS

| | |
|---------------|-------------------------------|
| Function type | Single-acting (SA) |
| Valve opening | Normally Open (NO) |
| Valve closing | pressure of fluid flow air |

ACTUATOR CAPACITY

L: litre, equivalent to 10^{-3} m^3
 Air consumption in normal litres (or normal cubic metres) per operating cycle can be calculated by correcting according to operating conditions such as control air pressure.

| | | | | | | | |
|----|--------|--------|--------|--------|--------|--------|--------|
| DN | 15 | 20 | 25 | 32 | 40 | 50 | 65 |
| NO | 0.13 L | 0.13 L | 0.28 L | 0.28 L | 0.50 L | 0.50 L | 0.50 L |

COMPRESSED AIR CONNECTIONS

| | |
|---------------|--------------------|
| Function type | Normally Open (NO) |
| Valve opening | - |
| Valve closing | Inlet A |

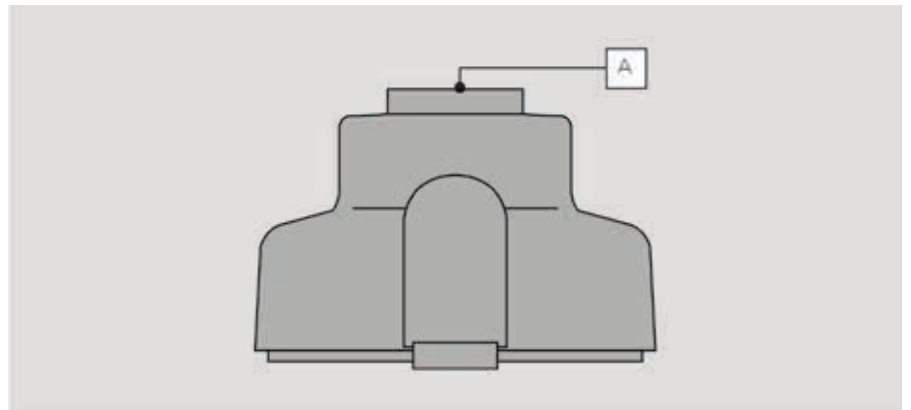

DIMENSIONS

DKD/CP DN 15÷65 PVC-U

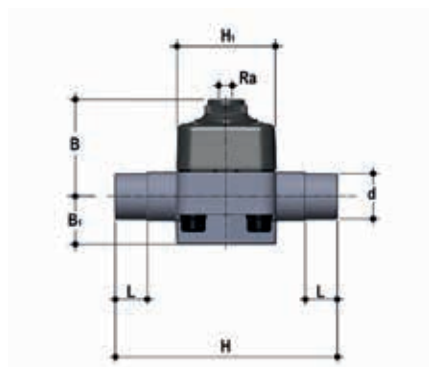

DKDDV/CP NO

Pneumatically actuated diaphragm valve, Normally Open, with male ends, metric series

| d | DN | PN | B | B _r | H | h | H ₁ | L | R _s | g | EPDM Code |
|----|----|----|-----|----------------|-------|----|----------------|----|----------------|------|-------------|
| 20 | 15 | 8 | 58 | 25 | 124 | 12 | 65 | 16 | 1/4" | 270 | DKDDVNO020E |
| 25 | 20 | 8 | 61 | 29.5 | 144 | 12 | 65 | 19 | 1/4" | 292 | DKDDVNO025E |
| 32 | 25 | 8 | 70 | 33 | 154.5 | 12 | 70 | 22 | 1/4" | 492 | DKDDVNO032E |
| 40 | 32 | 8 | 72 | 30 | 174.5 | 12 | 70 | 26 | 1/4" | 536 | DKDDVNO040E |
| 50 | 40 | 8 | 87 | 35 | 195.5 | 16 | 99 | 31 | 1/4" | 1100 | DKDDVNO050E |
| 63 | 50 | 8 | 109 | 46 | 225 | 16 | 114 | 38 | 1/4" | 1924 | DKDDVNO063E |
| 75 | 65 | 8 | 109 | 46 | 284 | 16 | 114 | 44 | 1/4" | 2045 | DKDDVNO075E |

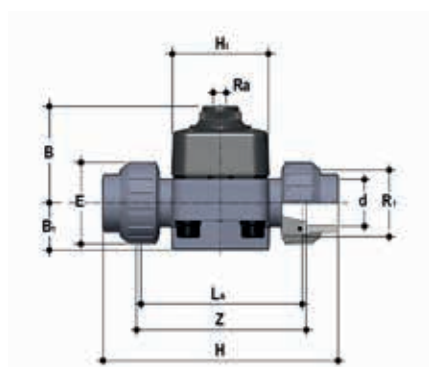

DKDUIV/CP NO

Pneumatically actuated diaphragm valve, Normally Open, with female union ends, metric series

| d | DN | PN | B | B _r | E | H | h | H ₁ | L _s | R _i | R _s | Z | g | EPDM Code |
|----|----|----|-----|----------------|----|-----|----|----------------|----------------|----------------|----------------|-----|------|--------------|
| 20 | 15 | 8 | 58 | 25 | 41 | 129 | 12 | 65 | 90 | 1" | 1/4" | 100 | 310 | DKDUIVNO020E |
| 25 | 20 | 8 | 61 | 29.5 | 50 | 154 | 12 | 65 | 108 | 1 1/4" | 1/4" | 116 | 372 | DKDUIVNO025E |
| 32 | 25 | 8 | 70 | 33 | 58 | 168 | 12 | 70 | 116 | 1 1/2" | 1/4" | 124 | 600 | DKDUIVNO032E |
| 40 | 32 | 8 | 72 | 30 | 72 | 192 | 12 | 70 | 134 | 2" | 1/4" | 140 | 726 | DKDUIVNO040E |
| 50 | 40 | 8 | 87 | 35 | 79 | 222 | 16 | 99 | 154 | 2 1/4" | 1/4" | 160 | 1312 | DKDUIVNO050E |
| 63 | 50 | 8 | 109 | 46 | 98 | 266 | 16 | 114 | 184 | 2 3/4" | 1/4" | 190 | 2320 | DKDUIVNO063E |

DIMENSIONS

DKD/CP DN 15÷65 PVC-U

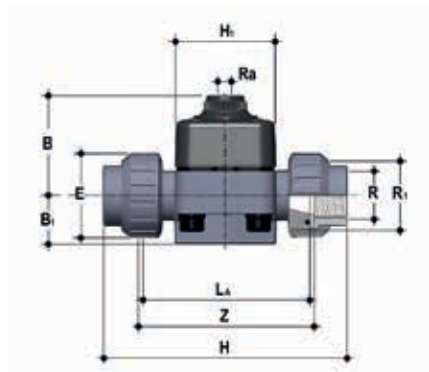

DKDUFV/CP NO

Pneumatically actuated diaphragm valve, Normally Open, with BSP threaded female union ends,

| R | DN | PN | B | B ₁ | H | h | H ₁ | L ₁ | Z | E | R ₁ | R ₂ | g | EPDM Code |
|--------|----|----|-----|----------------|-----|----|----------------|----------------|-----|----|----------------|----------------|------|--------------|
| 1/2" | 15 | 8 | 58 | 25 | 131 | 12 | 65 | 90 | 97 | 41 | 1" | 1/4" | 310 | DKDUFVNO012E |
| 3/4" | 20 | 8 | 61 | 29.5 | 151 | 12 | 65 | 108 | 118 | 50 | 1 1/4" | 1/4" | 372 | DKDUFVNO034E |
| 1" | 25 | 8 | 70 | 33 | 165 | 12 | 70 | 116 | 127 | 58 | 1 1/2" | 1/4" | 600 | DKDUFVNO100E |
| 1 1/4" | 32 | 8 | 72 | 30 | 188 | 12 | 70 | 134 | 145 | 72 | 2" | 1/4" | 726 | DKDUFVNO114E |
| 1 1/2" | 40 | 8 | 87 | 35 | 208 | 16 | 99 | 154 | 165 | 79 | 2 1/4" | 1/4" | 1312 | DKDUFVNO112E |
| 2" | 50 | 8 | 109 | 46 | 246 | 16 | 114 | 184 | 195 | 98 | 2 3/4" | 1/4" | 2320 | DKDUFVNO200E |

FASTENING AND SUPPORTING

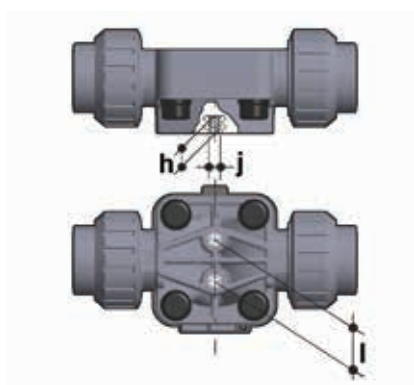

All valves, whether manual or actuated, must be adequately supported in many applications.

The DK valve series is therefore provided with an integrated bracket that permits direct anchoring of the valve body without the need of other components.

For wall or panel installation, dedicated PMDK mounting plates which are available as accessories can be used. These plates should be fastened to the valve before wall installation.

PMDK plates also allow DKD valve alignment with FIP ZIKM pipe clips.

| d | DN | h | l | J |
|----|----|----|------|----|
| 20 | 15 | 10 | 25 | M6 |
| 25 | 20 | 10 | 25 | M6 |
| 32 | 25 | 10 | 25 | M6 |
| 40 | 32 | 10 | 25 | M6 |
| 50 | 40 | 13 | 44.5 | M8 |
| 63 | 50 | 13 | 44.5 | M8 |
| 75 | 65 | 13 | 44.5 | M8 |

* With bracketing bushes

COMPONENTS

EXPLODED VIEW

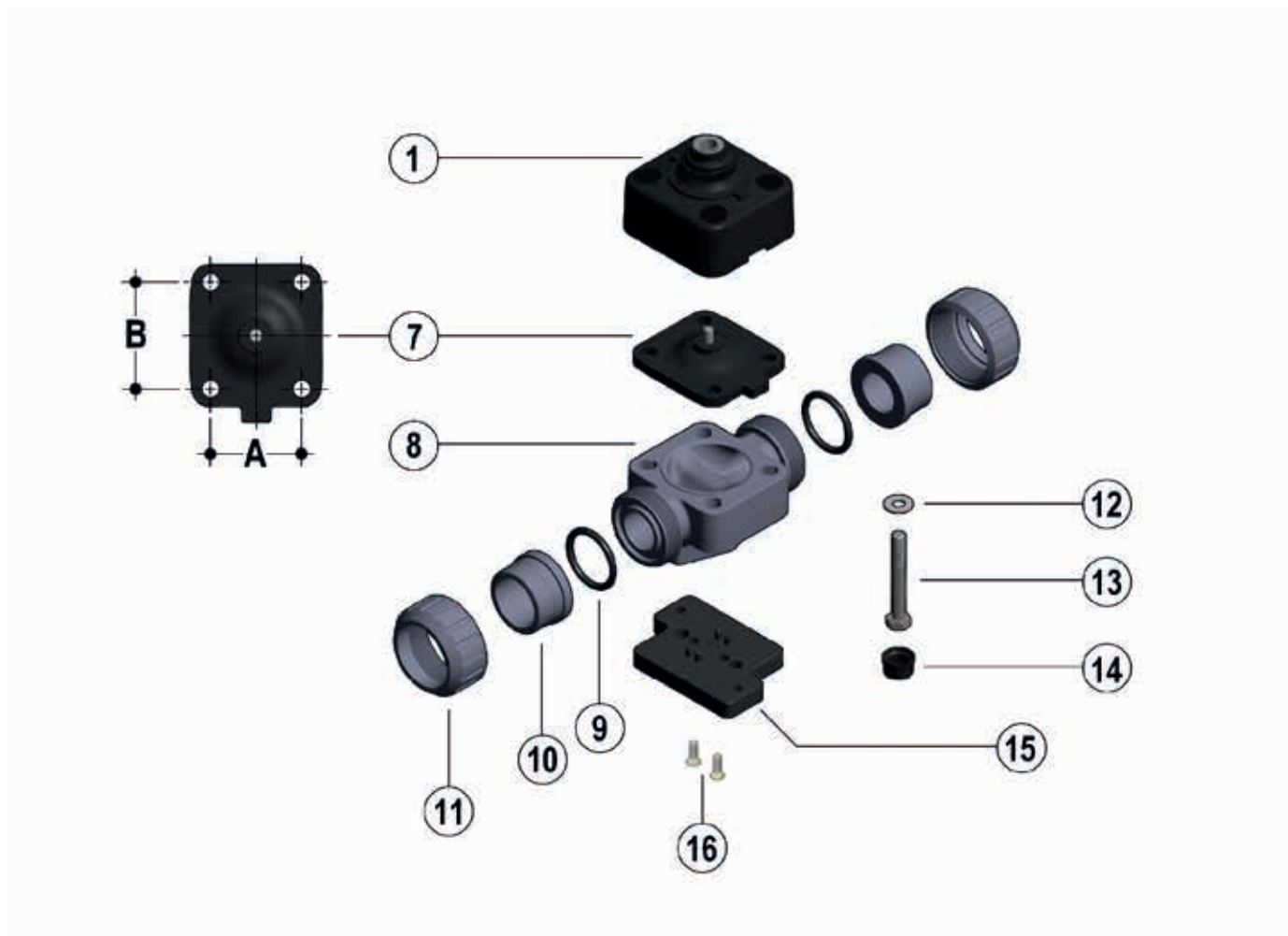

| DN | 15 | 20 | 25 | 32 | 40 | 50 | 65 |
|----|----|----|----|----|----|----|----|
| A | 40 | 40 | 46 | 46 | 65 | 78 | 78 |
| B | 44 | 44 | 54 | 54 | 70 | 82 | 82 |

1 Seal bonnet (PP-GR - 1)*

7 Seal diaphragm (EPDM - 1)*

8 Valve body (PVC-U - 1)*

9 Socket seal O-Ring (EPDM - 2)*

10 End connector (PVC-U - 2)*

11 Union nut (PVC-U - 2)*

12 Washer (Acciaio INOX - 4)

13 Bolt (Acciaio INOX - 4)

14 Protection plug (PE - 4)

* Spare parts

The material the component is made of and the quantity supplied are shown in brackets

DISASSEMBLY

- 1) Isolate the valve from the line (release the pressure and empty the pipeline).
- 2) Disconnect the valve from the pneumatic and electrical connections.
- 3) Unscrew the union nuts (11) and extract the valve.
- 4) Remove the protection plugs (14) and remove the bolts (13) with the relative washers (12).
- 5) Separate the valve body (8) from the sealing bonnet (1) and from the diaphragm (7).

ASSEMBLY

- 1) Rest the diaphragm (7) on the valve body (8).
- 2) Assemble the sealing bonnet (1) on the diaphragm (7) and tighten the bolts (13) with the relative washers (12).
- 3) Tighten the bolts (13) evenly (diagonally) to the tightening torque suggested on the relative instruction sheet.
- 4) Replace the protection plugs (14).
- 5) Position the valve between the end connectors (10) and tighten the union nuts (11), making sure that the socket seal O-rings (9) do not exit their seats.
- 6) Reconnect the valve to the pneumatic and electrical connections.



Note: All operations on equipment under pressure or containing compressed springs must be carried out under safe conditions for the operator.

INSTALLATION

Before proceeding with installation, please follow these instructions carefully: (instructions refer to versions with union ends). The valve can be installed in any position and in any direction.

- 1) Check that the pipes to be connected to the valve are aligned in order to avoid mechanical stress on the threaded joints.
- 2) Unscrew the union nuts (11) and insert them on the pipe segments.
- 3) Solvent weld or screw the end connectors (10) onto the pipe ends.
- 4) Position the valve body between the end connectors making sure the socket seal O-Rings (9) do not exit the seats.
- 5) Completely tighten the union nuts (11).
- 6) If necessary, support the pipework with FIP pipe clips or by means of the carrier built into the valve itself (see paragraph "Fastening and supporting").
- 7) Connect the compressed air as indicated in paragraph "Compressed air connections". For valves with electric accessories, refer to the specific technical manual supplied with the accessory.

WARNINGS

Note: before putting the valve into service, check that the bolts on the valve body (8) are tightened correctly at the torque indicated in the instruction sheet.