

SSE DN 65÷100

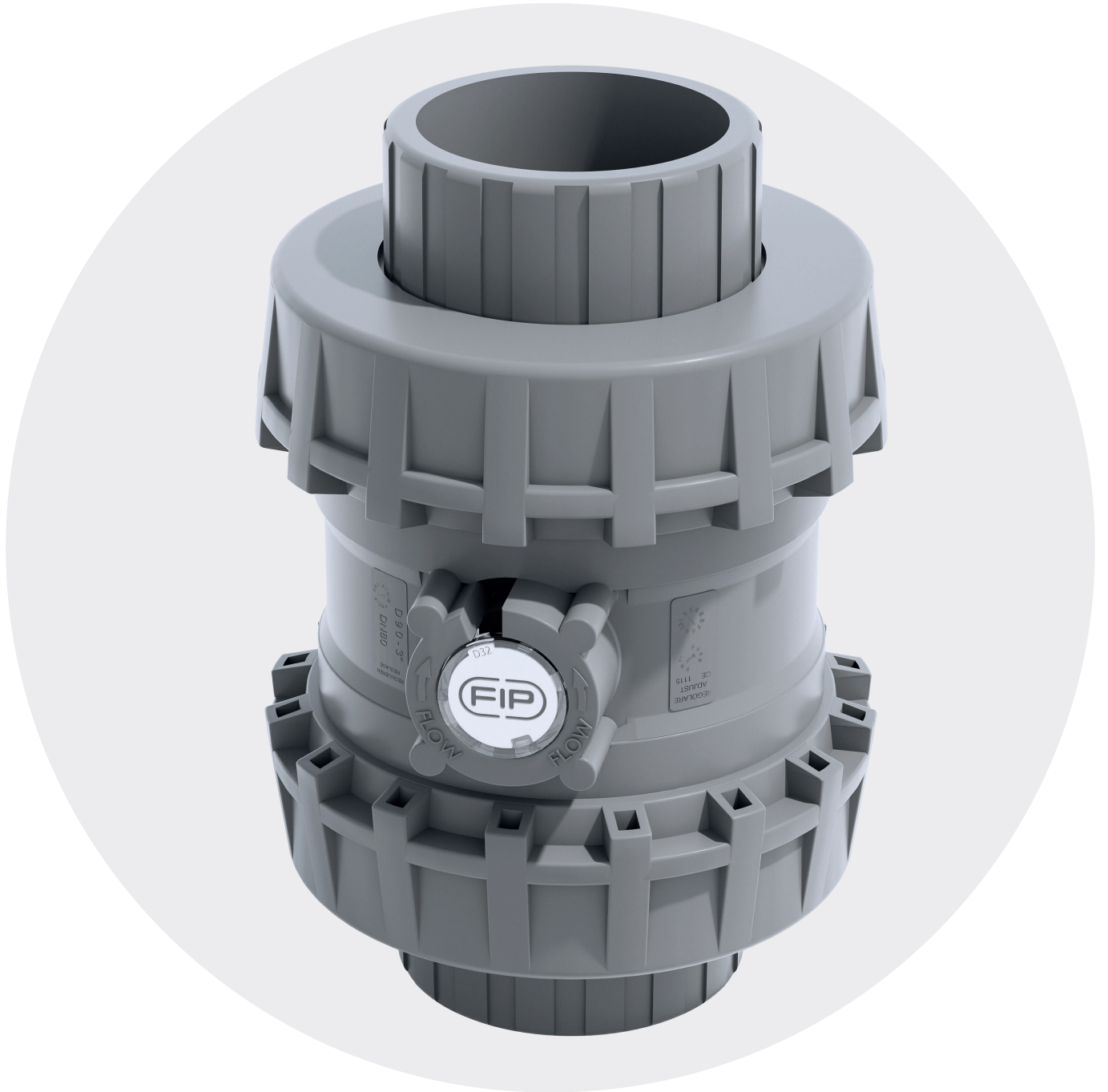

EASYFIT TRUE UNION BALL CHECK VALVE



SSE DN 65÷100

The SSE Easyfit check valve with spring loaded shutter developed with Giugiaro Design stands out for the innovative installation method that guarantees reliable service over time. This valve is also equipped with a customising Labelling System.



EASYFIT TRUE UNION BALL CHECK VALVE

- Connection system for solvent weld and threaded joints
- Valve material compatibility (**PVC-C**) with **water conveyance, drinking water and other food substances according to** current regulations
- **PN16 True Union valve body** made for PVC-C injection moulding and European Directive 2014/68/EU (PED) compliant for pressurised equipment. ISO 9393 compliant test requirements
- Easy radial disassembly and fully interchangeable with VXE 65-100 valve models
- Union nut profile that perfectly adapts to the Easyfit multifunctional handle hooked insert (available as an accessory) that lets you control union nut rotation
- Can be **installed** in either a **vertical** or **horizontal** position

Technical specifications	
Construction	Easyfit True Union spring check valve
Size range	DN 65 ÷ 100
Nominal pressure	PN 16 with water at 20° C
Temperature range	0 °C ÷ 100 °C
Coupling standards	Solvent welding: EN ISO 15493, ASTM F 439, Can be coupled to pipes according to EN ISO 15493, ASTM F 441 Thread: ISO 228-1, EN 10226-1/2, ASTM F 437
Reference standards	Construction criteria: EN ISO 16135, EN ISO 15493 Test methods and requirements: ISO 9393 Installation criteria: DVS 2204, DVS 2221, UNI 11242
Valve material	PVC-C
Seal material	EPDM, FKM (standard size O-Ring)
Spring material (SSE)	Available in STAINLESS steel 316, A316 PTFE encapsulated

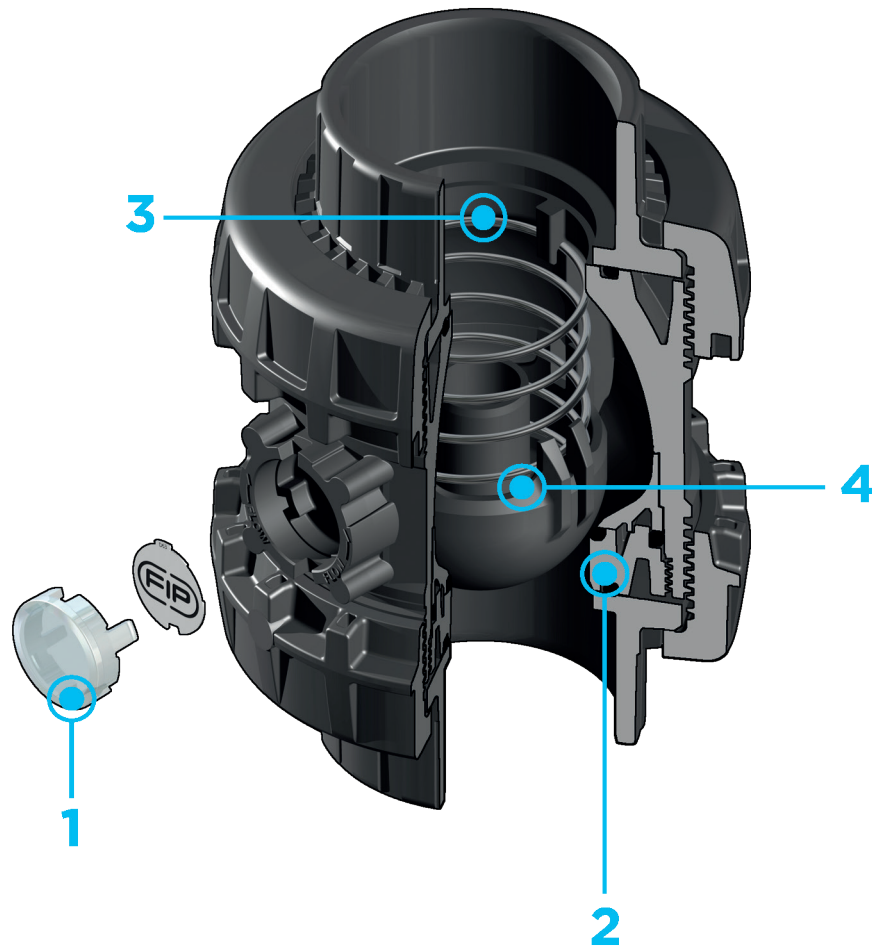

- 1 Customisable Labelling System: built-in LCE module** on the valve body made up of transparent protection plug and customisable tag holder using the LSE set (available as accessory). The customisation potential **lets you identify the valve on the system** according to specific needs
- 2 Locked ball seat carrier** safe dismantling for maintenance with the Easyfit multifunctional handle
- 3 Ideal for horizontal installations:** perfect seal even with low back pressure. Silent and durable even with strong vibrations and pulsating fluid
- 4 PVC-U shutter and springs** available in STAINLESS Steel 316, A316 PTFE encapsulated: maximum reliability in a wide field of applications from salt water to aggressive acids

TECHNICAL DATA

PRESSURE VARIATION ACCORDING TO TEMPERATURE

For water and harmless fluids to which the material is classified as CHEMICALLY RESISTANT. In other cases, a reduction of the nominal PN pressure is required (25 years with safety factor). Note: When using PVC-C at working temperatures higher than 90°, it is advisable to first contact the service centre.



PRESSURE DROP GRAPH

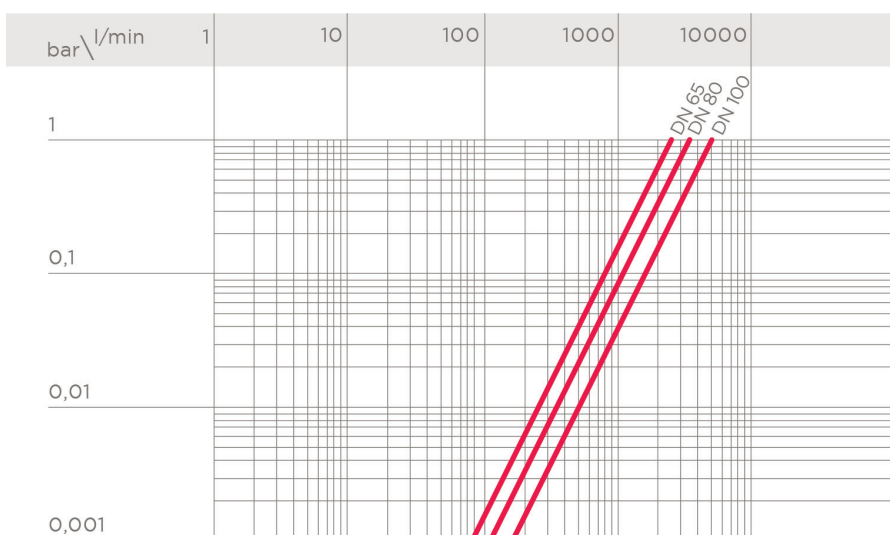

K_v100 FLOW COEFFICIENT

The K_v100 flow coefficient is the Q flow rate of litres per minute of water at a temperature of 20°C that will generate Δp= 1 bar pressure drop at a certain valve position. The Kv100 values shown in the table are calculated with the valve completely open.

DN	65	80	100
Kv100 l/min	2586	3444	5093

MINIMUM VALVE SEALING PRESSURE

The PVC-U SSE valve can only be used with liquids with specific weight under 1,37g/cm³.

DN	65	80	100
SSE (bar)	0,08	0,08	0,08

The information in this leaflet is provided in good faith. No liability will be accepted concerning technical data that is not directly covered by recognised international standards. FIP reserves the right to carry out any modification. Products must be installed and maintained by qualified personnel.

DIMENSIONS

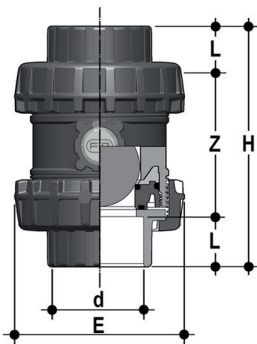

SXEIC

Easyfit ball check valve with female ends for solvent welding, metric series

d	DN	PN	E	H	L	Z	g	EPDM code	FKM code
75	65	16	157	211	44	123	2839	SXEIC075E	SXEIC075F
90	80	16	174	248	51	146	3597	SXEIC090E	SXEIC090F
110	100	16	212	283	61	161	6289	SXEIC110E	SXEIC110F

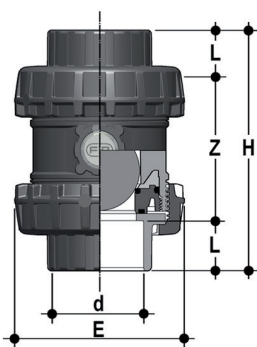

SXEAC

Easyfit ball check valve with female ends for solvent welding, ASTM series

d	DN	PN	E	H	L	Z	g	EPDM code	FKM code
2" 1/2	65	16	157	211	44,5	122	2839	SXEAC212E	SXEAC212F
3"	80	16	174	248	48	152	3597	SXEAC300E	SXEAC300F
4"	100	16	212	283	57,5	168	6289	SXEAC400E	SXEAC400F

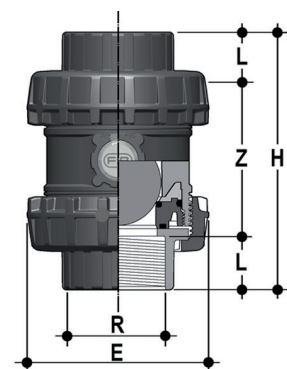

SXENC

Easyfit ball check valve with female ends, NPT thread

R	DN	PN	E	H	L	Z	g	EPDM code	FKM code
2" 1/2	65	16	157	211	33,2	144,6	2839	SXENC212E	SXENC212F
3"	80	16	174	248	35,5	177	3597	SXENC300E	SXENC300F
4"	100	16	212	283	37,6	207,8	6289	SXENC400E	SXENC400F

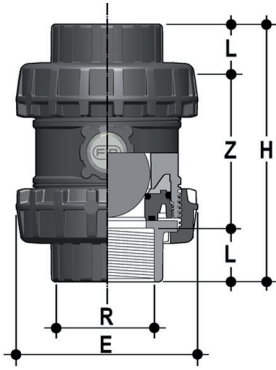

SXEFC

Easyfit ball check valve with BSP threaded female ends

R	DN	PN	E	H	L	Z	g	EPDM code	EPDM code
2" 1/2	65	16	157	211	30,2	150,6	2839	SXEFC212E	SXEFC212F
3"	80	16	174	248	33,3	181,4	3597	SXEFC300E	SXEFC300F
4"	100	16	212	283	39,3	204,4	6289	SXEFC400E	SXEFC400F

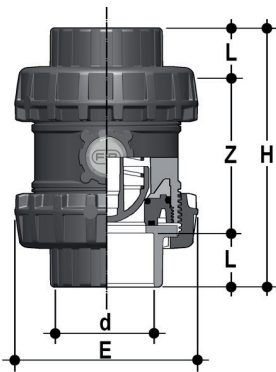

SSEIC - A316 Spring

Easyfit spring check valve with female ends for solvent welding, metric series

d	DN	PN	E	H	L	Z	g	EPDM code	FKM code
75	65	16	157	211	44	123	2652	SSEIC075E	SSEIC075F
90	80	16	174	248	51	146	3365	SSEIC090E	SSEIC090F
110	100	16	212	283	61	161	5898	SSEIC110E	SSEIC110F

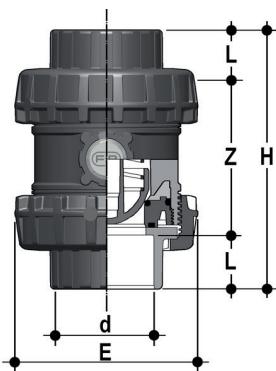

SSEIC - A316/PTFE encapsulated Spring

Easyfit spring check valve with female ends for solvent welding, metric series

d	DN	PN	E	H	L	Z	g	EPDM code	FKM code
75	65	16	157	211	44	123	2652	SSEIC075E0P	SSEIC075F0P
90	80	16	174	248	51	146	3365	SSEIC090E0P	SSEIC090F0P
110	100	16	212	283	61	161	5898	SSEIC110E0P	SSEIC110F0P

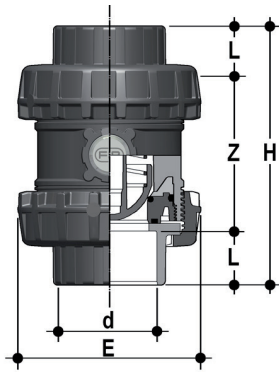

SSEAC - A316 Spring

Easyfit spring check valve with female ends for solvent welding, ASTM series

d	DN	PN	E	H	L	Z	g	EPDM code	FKM code
2" 1/2	65	16	157	211	44,5	122	2654	SSEAC212E	SSEAC212F
3"	80	16	174	248	48	152	3321	SSEAC300E	SSEAC300F
4"	100	16	212	283	57,5	168	5870	SSEAC400E	SSEAC400F

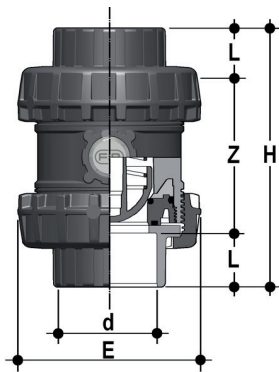

SSEAC - A316/PTFE encapsulated Spring

Easyfit spring check valve with female ends for solvent welding, ASTM series

d	DN	PN	E	H	L	Z	g	EPDM code	FKM code
2" 1/2	65	16	157	211	44,5	122	2654	SSEAC212E0P	SSEAC212F0P
3"	80	16	174	248	48	152	3321	SSEAC300E0P	SSEAC300F0P
4"	100	16	212	283	57,5	168	5870	SSEAC400E0P	SSEAC400F0P

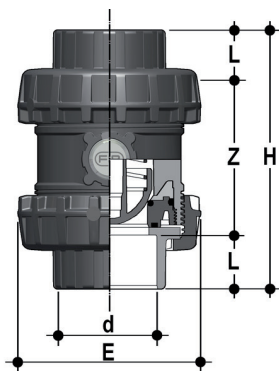

SSEIC

True Union Check Valve Easyfit with metric plain socket ends for solvent welding

d	DN	PN	E	H	L	Z	g	EPDM code	FKM code
75	65	16	157	211	44	123	2652	SSEIC075E	SSEIC075F
90	80	16	174	248	51	146	3365	SSEIC090E	SSEIC090F
110	100	16	212	283	61	161	5898	SSEIC110E	SSEIC110F

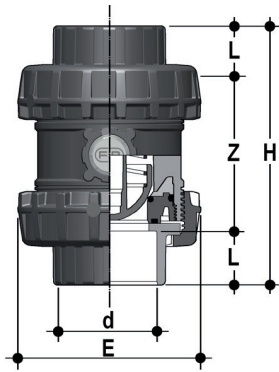

SSEAC

True Union Check Valve Easyfit with ASTM plain socket ends for solvent welding

d	DN	PN	E	H	L	Z	g	EPDM code	FKM code
2" 1/2	65	16	157	211	44,5	122	2654	SSEAC212E	SSEAC212F
3"	80	16	174	248	48	152	3321	SSEAC300E	SSEAC300F
4"	100	16	212	283	57,5	168	5870	SSEAC400E	SSEAC400F

ACCESSORIES

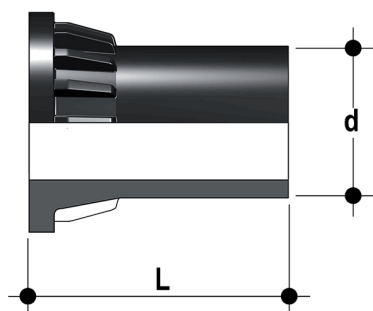

CVDE

Long spigot PE100 end connectors for joints with electrofusion fittings or for butt welding

d	DN	PN	L	SDR	Code
75	65	16	111	11	CVDE11075
90	80	10	118	11	CVDE11090VXE
110	100	10	127	11	CVDE11110VXE

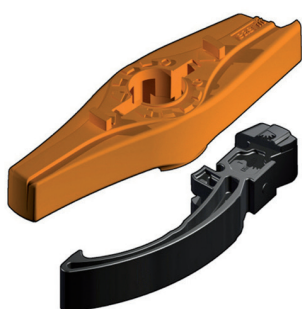

EASYFIT HANDLE DN 65÷100

Easyfit multifunctional handle for union nut tightening SXE-SSE DN 65÷100

d	DN	Code
75	65	HSVXE075
90	80	HSVXE090
110	100	HSVXE110



LSE

Customisation and label printing set for Easyfit handle made up of precut adhesive sheets and software for guided label creation.

d	DN	SXE - SSE code
75	65	LSE063
90	80	LSE063
110	100	LSE063

CUSTOMISATION



SSE DN 65÷100 Easyfit valve is equipped with a customisable Labelling System. This system lets you create special labels to affix to the valve body. This makes it extremely easy to apply company logos, identification serial numbers or service indications such as, for example, the valve function in the system, the transported fluid, but also specific information for customer service, such as the customer name or installation date or location on the valves.

The specific LCE module is a standard supply and is made up of a rigid transparent water-resistant PVC plug and white tag holder made of the same material, one side of which bears the FIP logo.

The holder, inserted in the plug, can be removed and, once overturned, used for customisation by applying labels printed with the software supplied with the LSE set.

Proceed as follows to apply the label on the valve:

- 1) Remove the transparent plug from the housing on the valve body.
- 2) Extract the tag holder from the transparent plug.
- 3) Apply the adhesive label on the holder to align the profiles matching the tab position.
- 4) Reinsert the tag holder in the transparent plug so that the label is protected against the elements.
- 5) Replace the transparent plug in its seat on the valve body.

COMPONENTS

EXPLODED VIEW

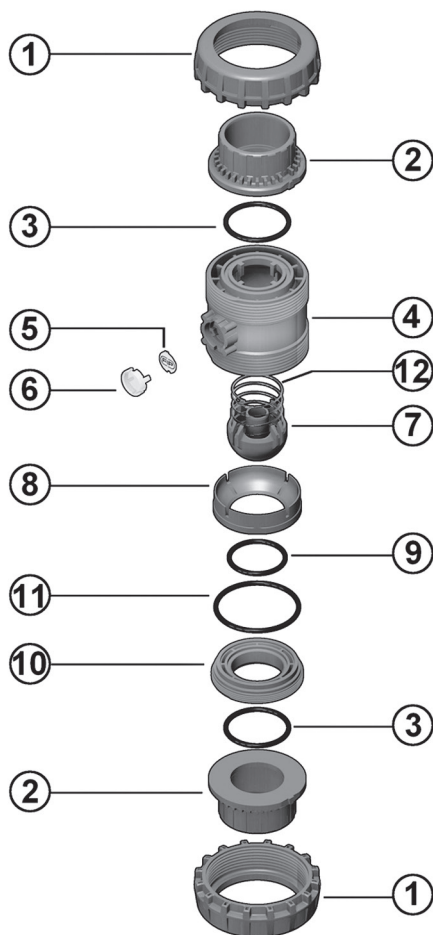

1 Union nut (PVC-C - 2)

2 End connector (PVC-C - 2)

3 Socket seal O-Ring (EPDM, FKM - 2)

4 Body (PVC-C - 1)

5 Tag holder (PVC - 1)

6 Transparent protection plug (PVC - 1)

7 Shutter (PVC-C - 1)

8 Gland packing ring (PVC-C - 1)

9 Shutter gasket (EPDM, FKM - 1)

10 Shutter seat O-ring (PVC-C - 1)

11 Radial seal O-Ring (EPDM,FKM - 1)

12 Spring (STAINLESS steel* - 1)

The component material and quantity supplied are indicated in the parentheses.

DISASSEMBLY

In the event of leaks or wear, before performing maintenance, cut-off fluid upstream from the valve and make sure it is de-pressurised (downstream drain if necessary).

- 1) Fully drain residual liquid that could be aggressive for the operator and, if possible, circulate water to internally clean the valve.
- 2) For easy union nut tightening in assembly, use the Easyfit multifunctional handle (supplied as an accessory).
- 3) Unscrew the ball seat carrier (10) with the Easyfit multifunctional handle: introduce the two protrusion on the top of the handle in the grooves in the carrier (10) and unscrew, extracting it counter-clockwise.
- 4) Remove all internal components.

ASSEMBLY

- 1) Reconstruct the valve following the exploded view on the previous page.
- 2) Tighten the ball seat carrier (10) using the Easyfit multifunctional handle. This ensures optimal valve installation and operations (fig. 3).
- 3) Position the valve between the end connectors (2) and tighten the union nuts clockwise (1) using the Easyfit multifunctional handle (fig. 7) being sure the socket seal O-ring (3) does not exit the seats.



Note: during assembly operations, it is advisable to lubricate the rubber seals. Mineral oils are not recommended for this task as they react aggressively with EPDM rubber.

Fig. 1



Fig. 2



Fig. 3



Fig. 4



INSTALLATION

SSE valve can be installed both vertically (upward flow) and horizontally.

Before proceeding with installation, please follow these instructions carefully:

- 1) Check that the pipes to be connected to the valve are aligned in order to avoid mechanical stress on the threaded joints.
- 2) Unscrew the union nuts (1) from the body (4) and insert them in the pipe segments.
- 3) Solvent weld or screw the end connectors (2) onto the pipe segments.
- 4) Position the valve body between the end connectors (fig. 1).
- 5) Place the union nuts on the valve body and start tightening manually clockwise until they are hard to turn. Do not use wrenches or other tools that can damage the union nut surface (fig. 2).
- 6) For easy union nut tightening in assembly, use the Easyfit multifunctional handle (supplied as an accessory).
- 7) Extract the hooked insert in the handle (fig. 5) overturn it and fit it in the seat on the lower part of the handle (fig. 6).
- 8) Fit the tool on the external union nut profile until firmly and safely secured that allows for adequate torque without damaging the union nut in any way (fig. 7).
- 9) Repeat point 7 for the other union nut.
- 10) When tightened, remove the hooked insert and replace it in its seat in the handle.
- 11) If necessary, support the pipe with FIP pipe clip model ZIKM and DSM distance plates.

WARNINGS

Do not use compressed air or other gases to test thermoplastic lines.

Always avoid sudden closing manoeuvres and protect the valve against accidental manoeuvres.

Leave a straight section of pipe of length equal to 5 times the nominal diameter before and after the valve

Fig. 5



Fig. 6



Fig. 7



Fig. 8

