

VKD DN 10÷50

DUAL BLOCK® 2-WAY BALL VALVE



VKD DN 10÷50

FIP has developed a VKD DUAL BLOCK® 2-way ball valve to introduce a high reference standard in thermoplastic valve design. VKD is a True Union ball valve that meets the most stringent needs required by industrial applications.



DUAL BLOCK® 2-WAY BALL VALVE

- Connection system for solvent weld, threaded and flanged joints
- Patented **SEAT STOP®** ball carrier system that lets you micro-adjust ball seats and minimise the axial force effect
- Easy radial dismounting allowing quick replacement of O-rings and ball seats without any need for tools
- **PN16 True Union valve body** made for rigid PVC-C injection moulding equipped with built-in bores for actuation. ISO 9393 compliant test requisites
- Option of disassembling downstream pipes with the valve in the closed position
- Floating **full bore ball** with high surface finish
- **Carrier integrated** in the body for valve anchoring
- Ball seat carriers can be adjusted using the **Easytorque adjustment kit**
- **Valve material compatibility** (PVC-C) and elastomer **seal elements** (EPDM or FKM), with water, drinking water and other food substances as per **current regulations**
- Possibility to have handle with integrated LSQT limit micro switch, even as a retrofit in existing installations

Technical specifications	
Construction	2-way True Union ball valve with locked carrier and union nuts.
Size range	DN 10 ÷ 50
Nominal pressure	PN 16 with water at 20° C
Temperature range	0 °C ÷ 100 °C
Coupling standards	<p>Solvent welding: EN ISO 15493, ASTM F 439. Can be coupled to pipes according to EN ISO 15493, ASTM F 441</p> <p>Thread: ISO 228-1, EN 10226-1/2, ASTM F 437</p> <p>Flanging system: ISO 7005-1, EN ISO 15493, EN 558-1, EN 1092-1, ANSI B.16.5 cl. 150, JIS B 2220.</p>
Reference standards	<p>Construction criteria: EN ISO 16135, EN ISO 15493</p> <p>Test methods and requirements: ISO 9393</p> <p>Installation criteria: DVS 2204, DVS 2221, UNI 11242</p> <p>Actuator couplings: ISO 5211</p>
Valve material	PVC-C
Seal material	EPDM, FKM, On request FEP+FKM, FFKM (standard size O-Ring); PTFE (ball seats)
Control options	Manual control; electric actuator; pneumatic actuator

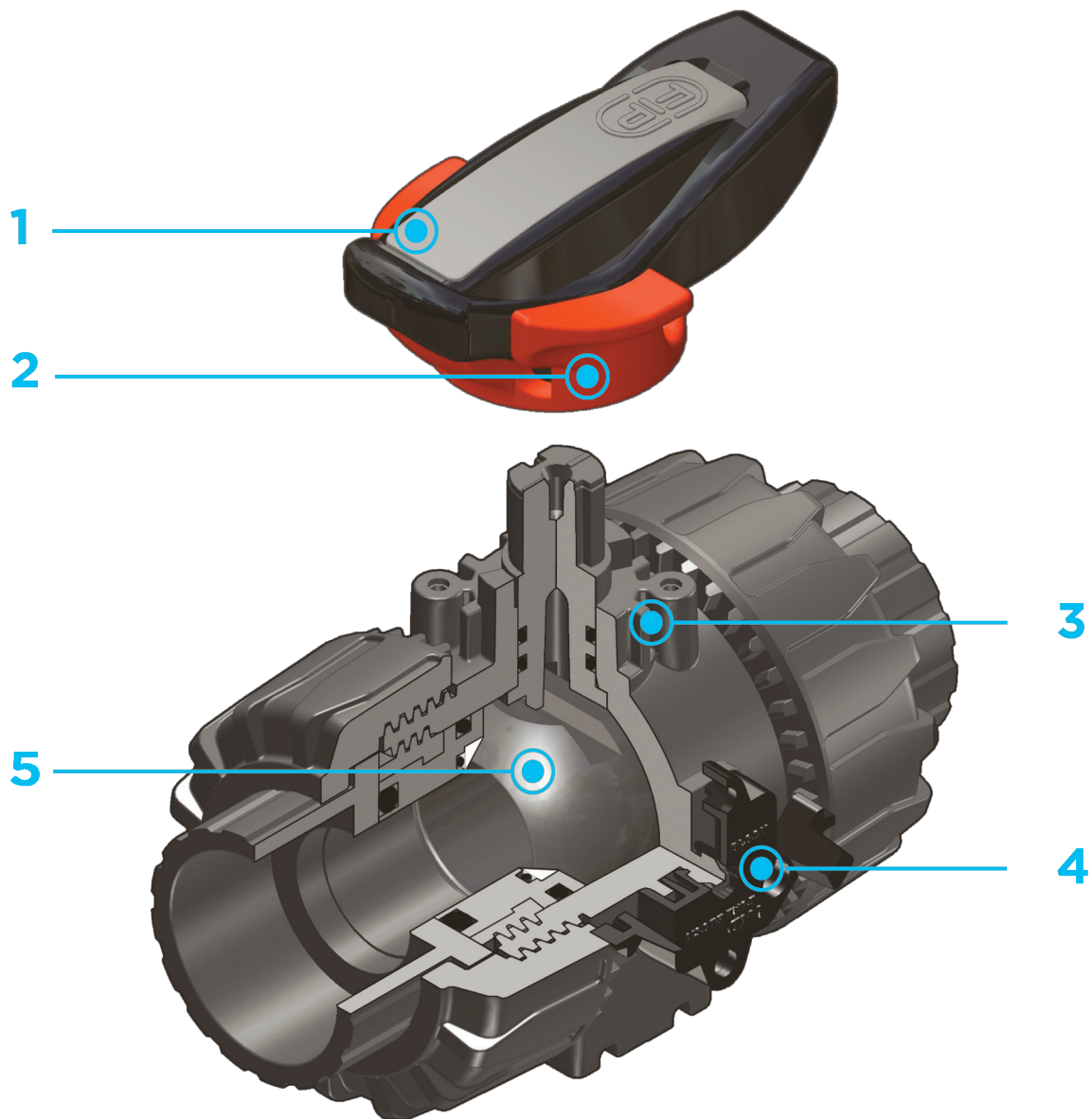

1 Ergonomic HIPVC handle equipped with **removable tool to adjust the ball seat carrier.**

2 **Handle lock 0°- 90° SHKD** (available as an accessory) ergonomically operable during service and padlockable

3 Robust **integrated bracket for valve anchoring**, for easy and quick automation even after valve installation on the system via the Power Quick module (optional)

4 **DUAL BLOCK®** patented lock system that ensures union nut

tightening hold even in severe conditions such as vibrations or heat dilation

5 Machined high surface finish ball that guarantees a smooth operation and increased reliability

TECHNICAL DATA

PRESSURE VARIATION ACCORDING TO TEMPERATURE

For water and harmless fluids to which the material is classified as CHEMICALLY RESISTANT. In other cases, a reduction of the nominal PN pressure is required (25 years with safety factor).



PRESSURE DROP GRAPH

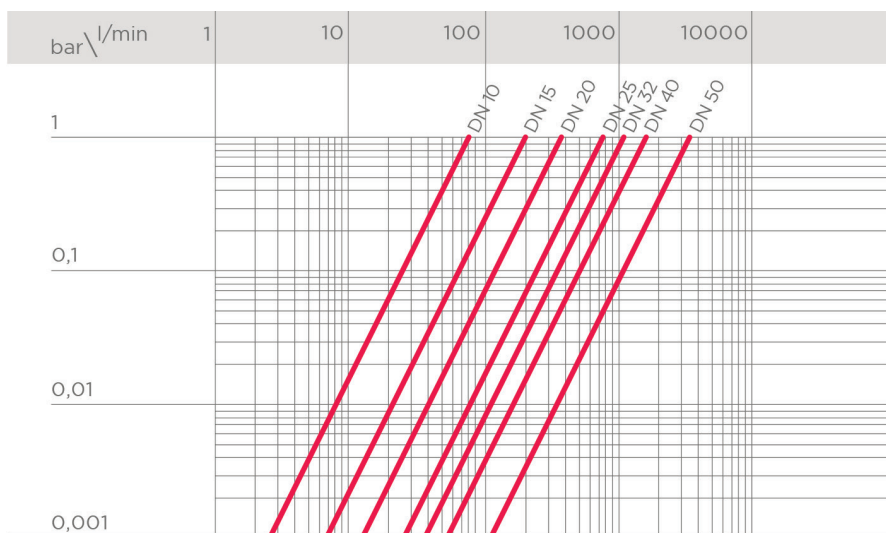

K_v100 FLOW COEFFICIENT

The K_v100 flow coefficient is the Q flow rate of litres per minute of water at a temperature of 20°C that will generate Δp= 1 bar pressure drop at a certain valve position. The Kv100 values shown in the table are calculated with the valve completely open.

DN	10	15	20	25	32	40	50
Kv100 l/min	80	200	385	770	1100	1750	3400

OPERATING TORQUE AT MAXIMUM WORKING PRESSURE

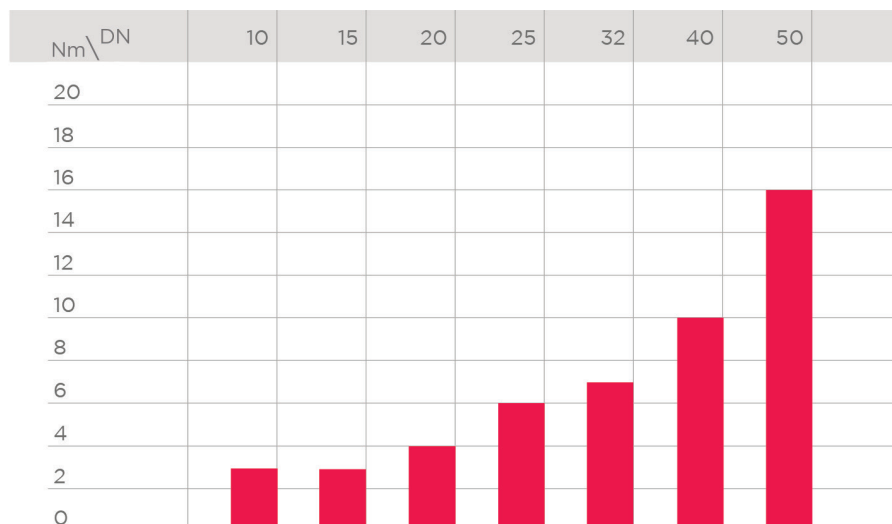

The information in this leaflet is provided in good faith. No liability will be accepted concerning technical data that is not directly covered by recognised international standards. FIP reserves the right to carry out any modification. Products must be installed and maintained by qualified personnel.

DIMENSIONS

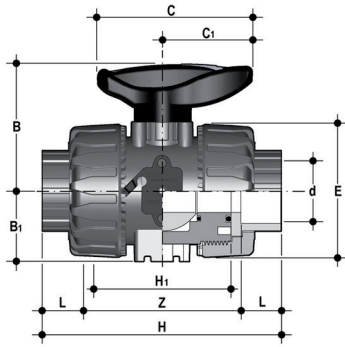

VKDIC

DUAL BLOCK® 2-way ball valve with female ends for solvent welding, metric series

d	DN	PN	B	B ₁	C	C ₁	E	H	H ₁	L	Z	g	EPDM code	FKM code
16	10	16	54	29	67	40	54	103	65	14	75	234	VKDIC016E	VKDIC016F
20	15	16	54	29	67	40	54	103	65	16	71	223	VKDIC020E	VKDIC020F
25	20	16	65	34,5	85	49	65	115	70	19	77	358	VKDIC025E	VKDIC025F
32	25	16	69,5	39	85	49	73	128	78	22	84	476	VKDIC032E	VKDIC032F
40	32	16	82,5	46	108	64	86	146	88	26	94	753	VKDIC040E	VKDIC040F
50	40	16	89	52	108	64	98	164	93	31	102	1007	VKDIC050E	VKDIC050F
63	50	16	108	62	134	76	122	199	111	38	123	1717	VKDIC063E	VKDIC063F

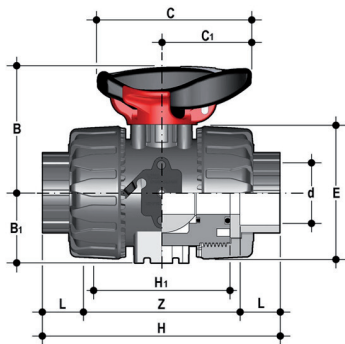

VKDIC/SHX

DUAL BLOCK® 2-way ball valve with female ends for solvent welding, metric series, handle block and STAINLESS steel threaded inserts

d	DN	PN	B	B ₁	C	C ₁	E	H	H ₁	L	Z	g	EPDM code	FKM code
16	10	16	54	29	67	40	54	103	65	14	75	244	VKDICSHX016E	VKDICSHX016F
20	15	16	54	29	67	40	54	103	65	16	71	233	VKDICSHX020E	VKDICSHX020F
25	20	16	65	34,5	85	49	65	115	70	19	77	368	VKDICSHX025E	VKDICSHX025F
32	25	16	69,5	39	85	49	73	128	78	22	84	486	VKDICSHX032E	VKDICSHX032F
40	32	16	82,5	46	108	64	86	146	88	26	94	763	VKDICSHX040E	VKDICSHX040F
50	40	16	89	52	108	64	98	164	93	31	102	1017	VKDICSHX050E	VKDICSHX050F
63	50	16	108	62	134	76	122	199	111	38	123	1727	VKDICSHX063E	VKDICSHX063F

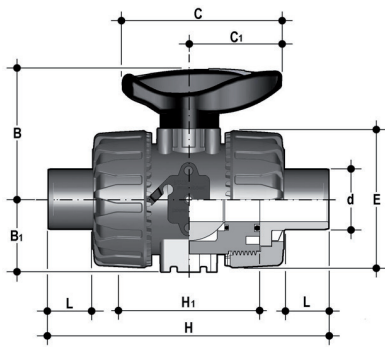

VKDDC

DUAL BLOCK® 2-way ball valve with male ends for solvent welding, metric series

d	DN	PN	B	B ₁	C	C ₁	E	H	H ₁	L	g	EPDM code	FKM code
20	15	16	54	29	67	40	54	124	65	16	239	VKDDC020E	VKDDC020F
25	20	16	65	34,5	85	49	65	144	70	19	369	VKDDC025E	VKDDC025F
32	25	16	69,5	39	85	49	73	154	78	22	482	VKDDC032E	VKDDC032F
40	32	16	82,5	46	108	64	86	174	88	26	753	VKDDC040E	VKDDC040F
50	40	16	89	52	108	64	98	194	93	31	1029	VKDDC050E	VKDDC050F
63	50	16	108	62	134	76	122	224	111	38	1749	VKDDC063E	VKDDC063F

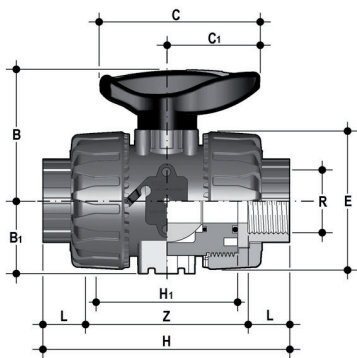

VKDFC

DUAL BLOCK® 2-way ball valve with BSP threaded female ends

R	DN	PN	B	B ₁	C	C ₁	E	H	H ₁	L	Z	g	EPDM code	FKM code
1/2"	15	16	54	29	67	40	54	111	65	17,8	75,4	228	VKDFC012E	VKDFC012F
3/4"	20	16	65	34,5	85	49	65	117	70	18	81	364	VKDFC034E	VKDFC034F
1"	25	16	69,5	39	85	49	73	135	78	22,6	89,8	487	VKDFC100E	VKDFC100F
1" 1/4	32	16	82,5	46	108	64	86	153	88	25,1	102,8	737	VKDFC114E	VKDFC114F
1" 1/2	40	16	89	52	108	64	98	156	93	24,7	106,6	1040	VKDFC112E	VKDFC112F
2"	50	16	108	62	134	76	122	186	111	29,6	126,8	1815	VKDFC200E	VKDFC200F

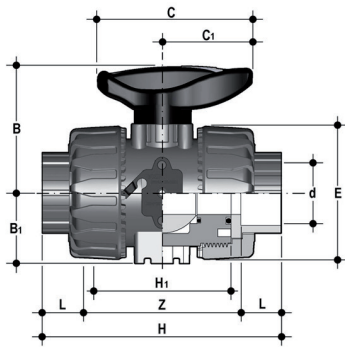

VKDAC

DUAL BLOCK® 2-way ball valve with female ends for solvent welding, ASTM series

d	DN	PN	B	B ₁	C	C ₁	E	H	H ₁	L	Z	g	EPDM code	FKM code
1/2"	15	16	54	29	67	40	54	117	65	22,5	72	234	VKDAC012E	VKDAC012F
3/4"	20	16	65	34,5	85	49	65	129	70	25,5	78	375	VKDAC034E	VKDAC034F
1"	25	16	69,5	39	85	49	73	142	78	28,7	84,6	487	VKDAC100E	VKDAC100F
1" 1/4	32	16	82,5	46	108	64	86	162	88	32	98	780	VKDAC114E	VKDAC114F
1" 1/2	40	16	89	52	108	64	98	172	93	35	102	1062	VKDAC112E	VKDAC112F
2"	50	16	108	62	134	76	122	199	111	38,2	122,6	1864	VKDAC200E	VKDAC200F

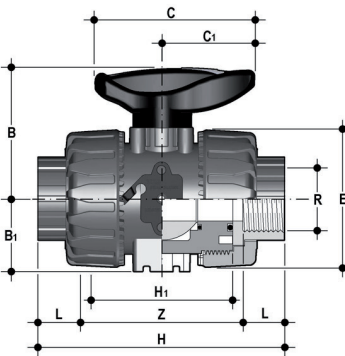

VKDNC

DUAL BLOCK® 2-way ball valve with female ends, NPT thread

R	DN	PN	B	B ₁	C	C ₁	E	H	H ₁	L	Z	g	EPDM code	FKM code
1/2"	15	16	54	29	67	40	54	111	65	17,8	75,4	228	VKDNC012E	VKDNC012F
3/4"	20	16	65	34,5	85	49	65	117	70	18	81	364	VKDNC034E	VKDNC034F
1"	25	16	69,5	39	85	49	73	135	78	22,6	89,8	487	VKDNC100E	VKDNC100F
1" 1/4	32	16	82,5	46	108	64	86	153	88	25,1	102,8	737	VKDNC114E	VKDNC114F
1" 1/2	40	16	89	52	108	64	98	156	93	24,7	106,6	1040	VKDNC112E	VKDNC112F
2"	50	16	108	62	134	76	122	186	111	29,6	126,8	1815	VKDNC200E	VKDNC200F

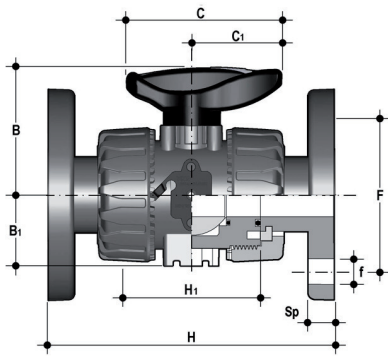

VKDOC

DUAL BLOCK® 2-way ball valve with fixed flanges, drilled EN/ISO/DIN PN10/16. Face to face according to EN 558-1

d	DN	PN	B	B ₁	C	C ₁	F	f	H	H ₁	Sp	U	g	EPDM code	FKM code
20	15	16	54	29	67	40	65	14	130	65	11	4	488,1	VKDOC020E	VKDOC020F
25	20	16	65	34,5	85	49	75	14	150	70	13,5	4	663,1	VKDOC025E	VKDOC025F
32	25	16	69,5	39	85	49	85	14	160	78	14	4	895,9	VKDOC032E	VKDOC032F
40	32	16	82,5	46	108	64	100	18	180	88	14	4	1379	VKDOC040E	VKDOC040F
50	40	16	89	52	108	64	110	18	200	93	16	4	1761	VKDOC050E	VKDOC050F
63	50	16	108	62	134	76	125	18	230	111	16	4	2741	VKDOC063E	VKDOC063F

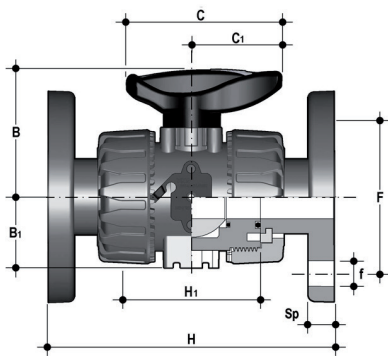

VKDOAC

DUAL BLOCK® 2-way ball valve with fixed flanges, drilled ANSI B16.5 cl.150 #FF

d	DN	PN	B	B ₁	C	C ₁	F	f	H	H ₁	Sp	U	g	EPDM code	FKM code
1/2"	15	16	54	29	67	40	60,3	15,9	143	65	11	4	481,1	VKDOAC012E	VKDOAC012F
3/4"	20	16	65	34,5	85	49	69,9	15,9	172	70	13,5	4	663,1	VKDOAC034E	VKDOAC034F
1"	25	16	69,5	39	85	49	79,4	15,9	187	78	14	4	895,9	VKDOAC100E	VKDOAC100F
1" 1/4	32	16	82,5	46	108	64	88,9	15,9	190	88	14	4	1379	VKDOAC114E	VKDOAC114F
1" 1/2	40	16	89	52	108	64	98,4	15,9	212	93	16	4	1761	VKDOAC112E	VKDOAC112F
2"	50	16	108	62	134	76	120,7	19,1	234	111	16	4	2741	VKDOAC200E	VKDOAC200F

ACCESSORIES

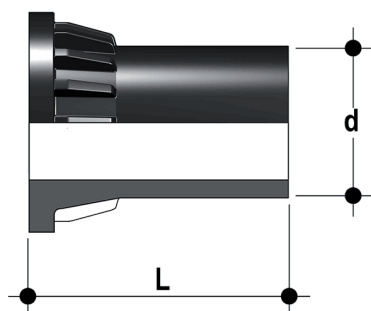

CVDE

Long spigot PE100 end connectors for joints with electrofusion fittings or for butt welding

d	DN	PN	L	SDR	Code
20	15	16	55	11	CVDE11020
25	20	16	70	11	CVDE11025
32	25	16	74	11	CVDE11032
40	32	16	78	11	CVDE11040
50	40	16	84	11	CVDE11050
63	50	16	91	11	CVDE11063



SHKD

Handle block kit 0° - 90° lockable

d	DN	Code
16 - 20	10 - 15	SHKD020
25 - 32	20 - 25	SHKD032
40 - 50	32 - 40	SHKD050
63	50	SHKD063

PMKD

Wall mounting plate

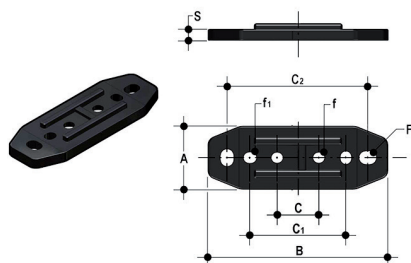

d	DN	A	B	C	C ₁	C ₂	F	f	f ₁	S	Code
16	10	30	86	20	46	67,5	6,5	5,3	5,5	5	PMKD1
20	15	30	86	20	46	67,5	6,5	5,3	5,5	5	PMKD1
25	20	30	86	20	46	67,5	6,5	5,3	5,5	5	PMKD1
32	25	30	86	20	46	67,5	6,5	5,3	5,5	5	PMKD1
40	32	40	122	30	72	102	6,5	6,3	6,5	6	PMKD2
50	40	40	122	30	72	102	6,5	6,3	6,5	6	PMKD2
63	50	40	122	30	72	102	6,5	6,3	6,5	6	PMKD2

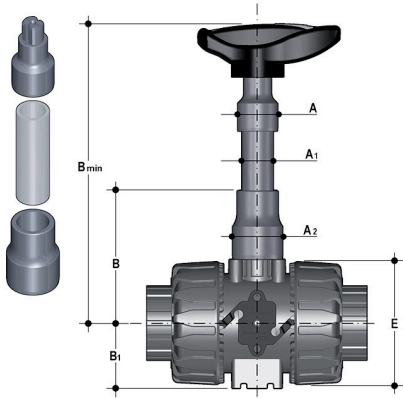

PSKD

Stem extension

d	DN	A	A ₁	A ₂	E	B	B ₁	B _{min}	Code
16	10	32	25	32	54	70	29	139,5	PSKD020
20	15	32	25	32	54	70	29	139,5	PSKD020
25	20	32	25	40	65	89	34,5	164,5	PSKD025
32	25	32	25	40	73	93,5	39	169	PSKD032
40	32	40	32	50	86	110	46	200	PSKD040
50	40	40	32	50	98	116	52	175	PSKD050
63	50	40	32	59	122	122	62	225	PSKD063



Easytorque Kit

Kit for ball seat carrier tightening adjustment for DUAL BLOCK® DN 10-50 series valves

d	DN	Tightening torque recommended*	Code
3/8"-1/2"	10-15	3 N m - 2,21 Lbf ft	KET01
3/4"	20	4 N m - 2,95 Lbf ft	KET01
1"	25	5 N m - 3,69 Lbf ft	KET01
1" 1/4	32	5 N m - 3,69 Lbf ft	KET01
1" 1/2	40	7 N m - 5,16 Lbf ft	KET01
2"	50	9 N m - 6,64 Lbf ft	KET01

*calculated in ideal installation conditions

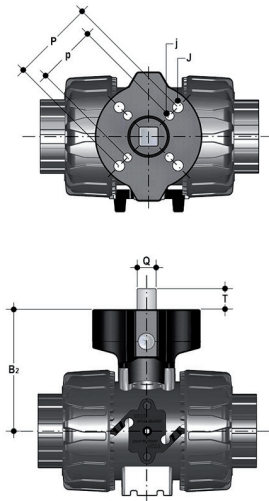

Power Quick/CP

The valve can be equipped with pneumatic actuators, using the PP-GR module reproducing the drilling pattern foreseen by ISO 5211

d	DN	B ₂	Q	T	p x j	P x J	Code
16	10	58	11	12	F03 x 5,5	F04 x 5,5	PQCP020
20	15	58	11	12	F03 x 5,5	F04 x 5,5	PQCP020
25	20	69	11	12	*F03 x 5,5	F05 x 6,5	PQCP025
32	25	74	11	12	*F03 x 5,5	F05 x 6,5	PQCP032
40	32	91	14	16	F05 x 6,5	F07 x 8,5	PQCP040
50	40	97	14	16	F05 x 6,5	F07 x 8,5	PQCP050
63	50	114	14	16	F05 x 6,5	F07 x 8,5	PQCP063

*F04 x 5.5 on request

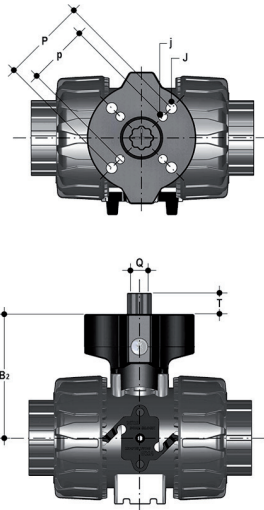

Power Quick/CE

The valve can be equipped with electric actuators, using the PP-GR module reproducing the drilling pattern foreseen by ISO 5211

d	DN	B ₂	Q	T	p x j	P x J	Code
16	10	58	14	16	F03 x 5,5	F04 x 5,5	PQCE020
20	15	58	14	16	F03 x 5,5	F04 x 5,5	PQCE020
25	20	69	14	16	*F03 x 5,5	F05 x 6,5	PQCE025
32	25	74	14	16	*F03 x 5,5	F05 x 6,5	PQCE032
40	32	91	14	16	F05 x 6,5	F07 x 8,5	PQCE040
50	40	97	14	16	F05 x 6,5	F07 x 8,5	PQCE050
63	50	114	14	16	F05 x 6,5	F07 x 8,5	PQCE063

*F04 x 5.5 on request

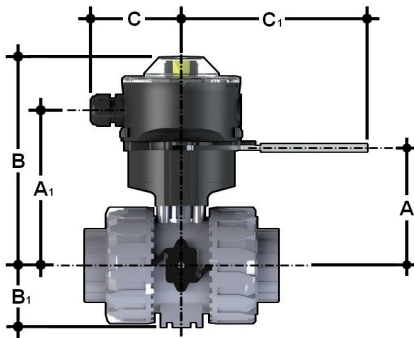

LS Quick Kit

The Limit Switch Quick Kit allows the fast and secure installation of the FIP LSQT to the VKD valves. The body is in PP-GR and the handle is in stainless steel AISI 316. The handle block at 0° and 90° is also available by default (hole diameter 6.5 mm). The kit can be assembled on the valve even if already installed on the system. For technical data of the LSQT box see FIP actuated valves catalogue.

d	DN	A	A ₁	B	B ₁	C	C ₁	Code
16	10	60	91,5	137	29	76,5	157,5	LSQKIT20
20	15	60	91,5	137	29	76,5	157,5	LSQKIT20
25	20	71	102,5	148	34,5	76,5	157,5	LSQKIT25
32	25	76	107,5	153	39	76,5	157,5	LSQKIT32
40	32	93	124,5	170	46	76,5	157,5	LSQKIT40
50	40	99	130,5	176	52	76,5	157,5	LSQKIT50
63	50	116	147,5	193	62	76,5	157,5	LSQKIT63

FASTENING AND SUPPORTING



All valves, whether manual or actuated, must be adequately supported in many applications. The VKD valve series is therefore ready to be equipped with threaded supporting brackets (optional) that permits direct anchoring of the valve body without the need of other components. For wall installation, dedicated PMKD mounting plates which are available as accessories can be used. These plates should be fastened to the valve before wall installation. PMKD plates also allow VKD valve alignment with FIP ZIKM pipe clips as well as allowing different sizes of valves to be aligned.

d	DN	g	H	L	J*
16	10	31,5	27	20	M4 x 6
20	15	31,5	27	20	M4 x 6
25	20	40	30	20	M4 x 6
32	25	40	30	20	M4 x 6
40	32	50	35	30	M6 x 10
50	40	50	35	30	M6 x 10
63	50	60	40	30	M6 x 10

* With threaded inserts

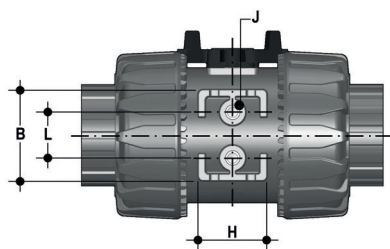

COMPONENTS

EXPLODED VIEW

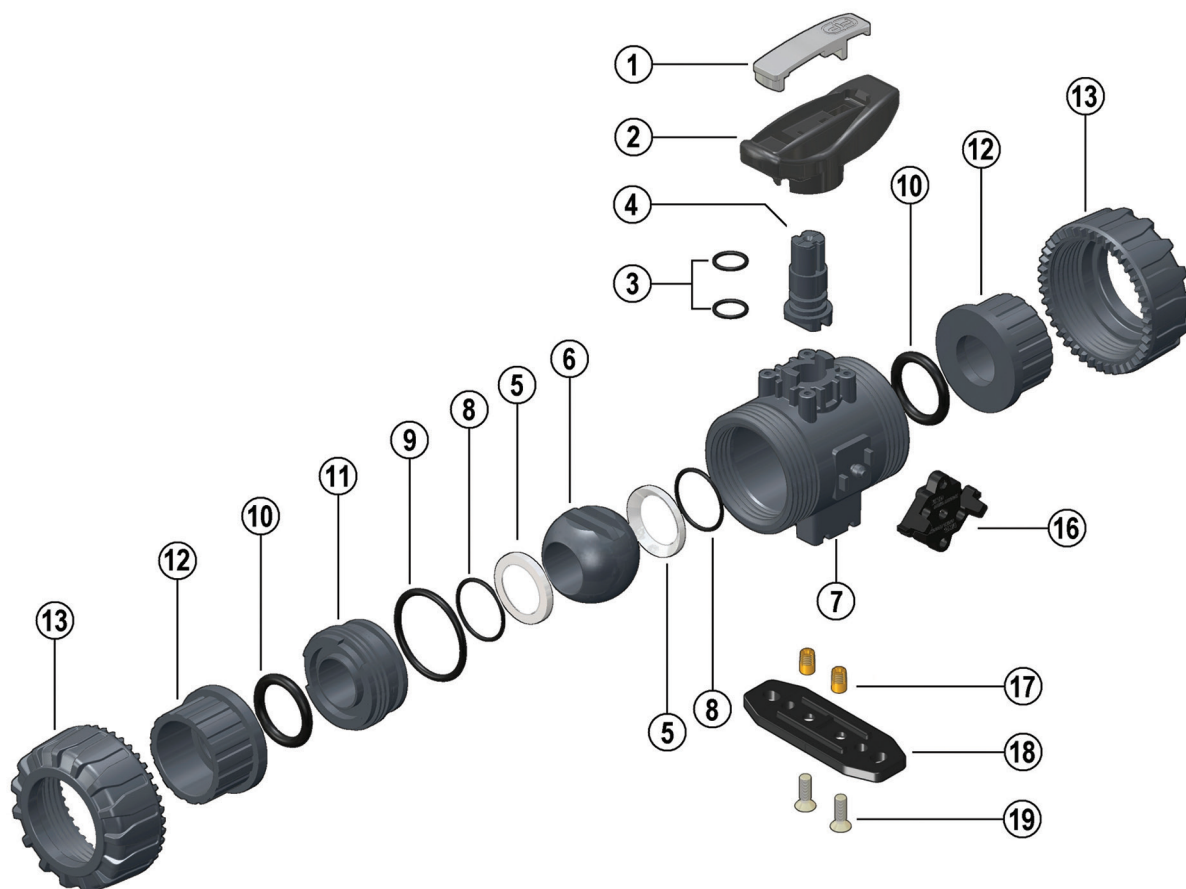

- | | | | | | |
|----------|------------------------------|-----------|---------------------------------------|-----------|---|
| 1 | Handle insert (PVC-U - 1) | 8 | Ball seat O-Rings (EPDM or FKM - 2)* | 14 | Spring (STAINLESS steel - 1)** |
| 2 | Handle (HIPVC - 1) | 9 | Radial seal O-Ring (EPDM or FKM - 1)* | 15 | Handle safety block (PP-GR - 1)** |
| 3 | Stem O-rings (EPDM-FKM - 2)* | 10 | Socket seal O-Ring (EPDM or FKM - 2)* | 16 | DUAL BLOCK® (POM - 1) |
| 4 | Stem (PVC-C - 1) | 11 | Ball seat carrier (PVC-C - 1) | 17 | Threaded inserts (STAINLESS steel or Brass - 2)** |
| 5 | Ball seat (PTFE - 2)* | 12 | End connector (PVC-C - 2)* | 18 | Distance plate (PP-GR - 1)** |
| 6 | Ball (PVC-C - 1) | 13 | Union nut (PVC-C - 2) | 19 | Screw (STAINLESS steel - 2)** |
| 7 | Body (PVC-C - 1) | | | | |

* Spare parts

** Accessories

The component material and quantity supplied are indicated in the parentheses.

INSTALLATION

Before proceeding with installation, please follow these instructions carefully:

- 1) Check that the pipes to be connected to the valve are aligned in order to avoid mechanical stress on the threaded joints.
- 2) Check that the DUAL BLOCK® union nut locking device (16) is fitted to the valve body.
- 3) To release the union nuts, axially press the release lever to separate the lock and then unscrew it in the counter-clockwise direction.
- 4) Unscrew the union nuts (13) and insert them on the pipe segments.
- 5) Solvent weld or screw the end connectors (12) onto the pipe ends.
- 6) Position the valve body between the end connectors and fully tighten the union nuts (13) manually by rotating clockwise without using wrenches or other tools that could damage the union nut surface.
- 7) Lock the union nuts by returning the DUAL BLOCK® to its housing, pressing on it until the hinges lock on the union nuts.
- 8) If necessary, support the pipework with FIP pipe clips or by means of the carrier built into the valve itself (see paragraph "fastening and carriers").

The VKD valve can be equipped with a handle lock to prevent ball rotation (supplied separately).

When the handle safety block (14, 15) is installed, lift the lever (15) and rotate the handle (fig. 6-7).

A lock can also be installed on the handle to protect the system against tampering (fig. 8).

Seal can be adjusted using the extractable insert on the handle (fig. 3-4).

The seals can be adjusted later with the valve installed on the pipe by simply tightening the union nuts. This "micro adjustment", only possible with FIP valves thanks to the patented "Seat stop system", allows the seal to be recovered where PTFE ball seats are worn due to a high number of operations. The Easytorque kit can also be used for micro adjustments (fig. 5).

WARNINGS

- If volatile liquid such as Hydrogen Peroxide (H₂O₂) or Sodium Hypochlorite (NaClO) are used, for safety reasons we recommend you contact the service centre. These liquids, upon vaporising, could create hazardous over pressures in the area between the body and ball.
- Always avoid sudden closing operations and protect the valve from accidental operations.

Fig.5



Fig.6



Fig.7



Fig.8

