

SXE-SSE DN 65÷100



Easyfit True Union ball and spring check valve



SXE-SSE DN 65÷100

The Easyfit check valve line developed with Giugiaro Design offers two different versions: SXE with ball shutter and SSE with spring loaded shutter. Easyfit check valves stand out for the innovative installation method that guarantees reliable service over time. This valve is also equipped with a customisable Labelling System.



EASYFIT TRUE UNION BALL AND SPRING CHECK VALVE

- Connection system for solvent weld and threaded joints
- **Valve material compatibility** (PVC-U) with water, drinking water and other food substance conveyance according to **current regulations**
- **PN16 True Union valve body** made for PVC-U injection moulding and European Directive 2014/68/EU (PED) compliant for pressurised equipment. ISO 9393 compliant test requirements
- Easy radial dismounting and fully interchangeable with VEE and VXE 65-100 valve models
- Union nut profile that perfectly adapts to the Easyfit multifunctional handle hooked insert (available as an accessory) that lets you control union nut rotation
- **Vertical** (preferable for SXE model) and **horizontal installation** potential

Technical specifications

Construction	SXE: Easyfit True Union ball check valve with locked carrier SSE: Easyfit True Union spring check valve with locked carrier
Size range	DN 65 ÷ 100
Nominal pressure	PN 16 with water at 20 °C
Temperature range	0 °C ÷ 60 °C
Coupling standards	Solvent welding: EN ISO 1452, EN ISO 15493, BS 4346-1, , NF T54-028, ASTM D 2467, JIS K 6743. Pipe coupling capacity according to EN ISO 1452, EN ISO 15493, DIN 8062, NF T54-016, ASTM D 1785, JIS K 6741. Thread: ISO 228-1, EN 10226-1/2, ASTM D 2464, JIS B 0203.
Reference standards	Construction criteria: EN ISO 16137, EN ISO 1452, EN ISO 15493 Test methods and requirements: ISO 9393 Installation criteria: DVS 2204, DVS 2221, UNI 11242
Valve material	PVC-U
Seal material	EPDM, FKM (standard size O-Ring)
Spring material (SSE)	Available in STAINLESS Steel 316, A316 PTFE encapsulated

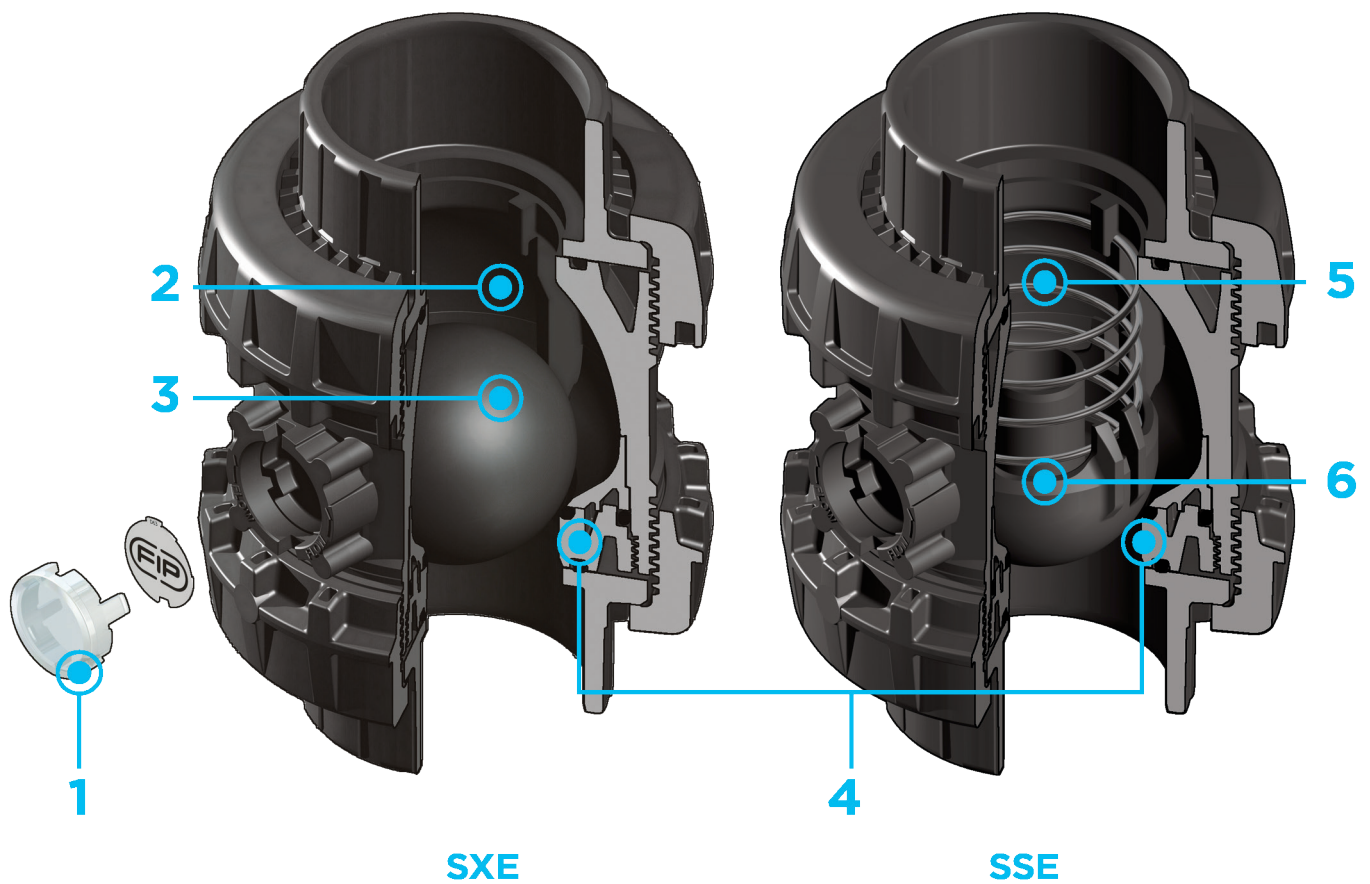

- 1 Customisable Labelling System: built-in LCE module** on the valve body made up of transparent protection plug and customisable tag holder using the LSE set (available as accessory). The customisation potential lets you **identify the valve on the system** according to specific needs
- 2 Optimised dynamic fluid design:** energy savings due to the improved valve Kv value and consequent reduced pressure drop
- 3 High surface finish ball shutter: reduced wear,** longer working life and reduced valve maintenance. Ideal to convey dirty fluids, even with suspended fluids or filaments, thanks to the special design that permits **internal valve selfcleaning**
- 4 Locked ball seat carrier:** safe dismantling for maintenance with the Easyfit multifunctional handle
- 5 Ideal for horizontal installations: perfect seal even with low back pressure. Silent** and durable even with strong vibrations and pulsating fluid
- 6 PVC-U shutter and springs** available in STAINLESS Steel 316, A316 PTFE encapsulated: maximum reliability in a **wide field of applications** from salt water to aggressive acids

TECHNICAL DATA

PRESSURE VARIATION ACCORDING TO TEMPERATURE

For water and harmless fluids to which the material is classified as CHEMICALLY RESISTANT. In other cases, a reduction of the nominal PN pressure is required (25 years with safety factor).



PRESSURE DROP GRAPH

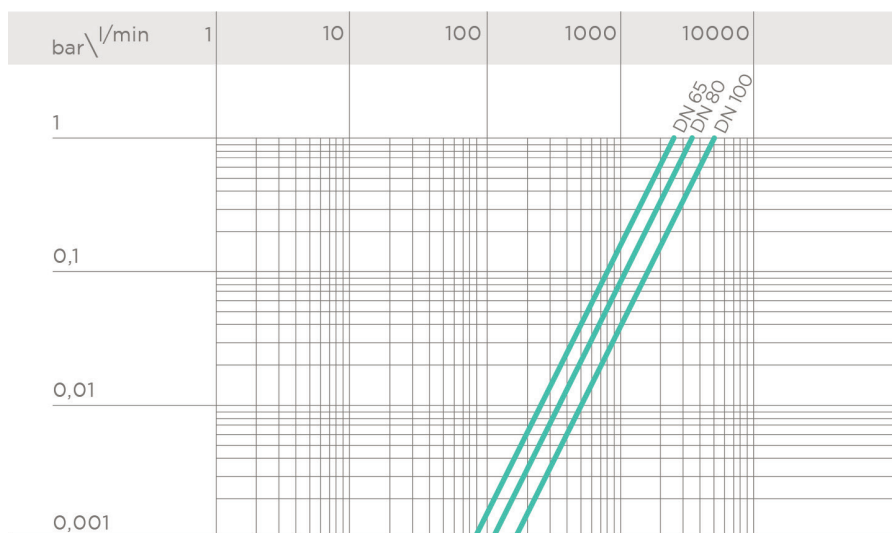

K_v100 FLOW COEFFICIENT

The K_v100 flow coefficient is the Q flow rate of litres per minute of water at a temperature of 20°C that will generate Δp= 1 bar pressure drop at a certain valve position. The Kv100 values shown in the table are calculated with the valve completely open.

DN	65	80	100
Kv100 l/min	2586	3444	5093

MINIMUM VALVE SEALING PRESSURE

The PVC-U SXE valve can only be used with liquids with specific weight under 1,37g/cm³.

DN	65	80	100
SXE (bar)	0,2	0,2	0,2
SSE (bar)	0,08	0,08	0,08

The information in this leaflet is provided in good faith. No liability will be accepted concerning technical data that is not directly covered by recognised international standards. FIP reserves the right to carry out any modification. Products must be installed and maintained by qualified personnel.

DIMENSIONS

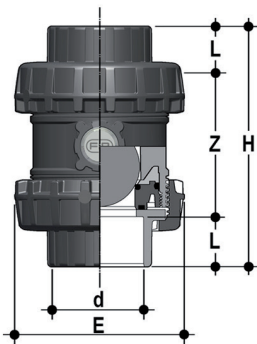

SXEIV

Easyfit ball check valve with female ends for solvent welding, metric series

d	DN	PN	E	H	L	Z	g	EPDM code	FKM code
75	65	16	157	211	44	123	2605	SXEIV075E	SXEIV075F
90	80	16	174	248	51	146	3300	SXEIV090E	SXEIV090F
110	100	16	212	283	61	161	5770	SXEIV110E	SXEIV110F

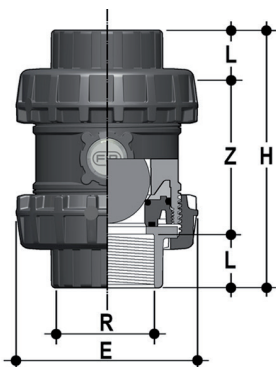

SXEFV

Easyfit ball check valve with BSP threaded female ends

R	DN	PN	E	H	L	Z	g	EPDM code	FKM code
2" 1/2	65	16	157	211	30,2	150,6	2605	SXEFV212E	SXEFV212F
3"	80	16	174	248	33,3	181,4	3300	SXEFV300E	SXEFV300F
4"	100	16	212	283	39,3	204,4	5770	SXEFV400E	SXEFV400F

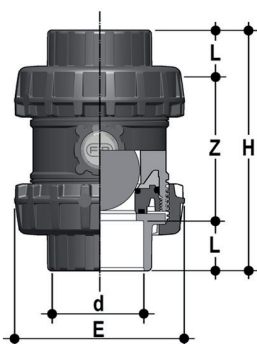

SXELV

Easyfit ball check valve with female ends for solvent welding, BS series

d	DN	PN	E	H	L	Z	g	EPDM code	FKM code
2" 1/2	65	16	157	211	44	123	2605	SXEIV075E	SXEIV075F
3"	80	16	174	248	51	146	3300	SXELV300E	SXELV300F
4"	100	16	212	283	63	157	5770	SXELV400E	SXELV400F

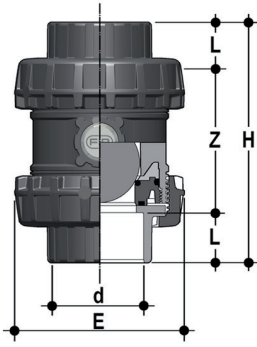

SXEAV

Easyfit ball check valve with female ends for solvent welding, ASTM series

d	DN	PN	E	H	L	Z	g	EPDM code	FKM code
2" 1/2	65	16	157	211	44,5	122	2605	SXEAV212E	SXEAV212F
3"	80	16	174	248	48	152	3300	SXEAV300E	SXEAV300F
4"	100	16	212	283	57,5	168	5770	SXEAV400E	SXEAV400F

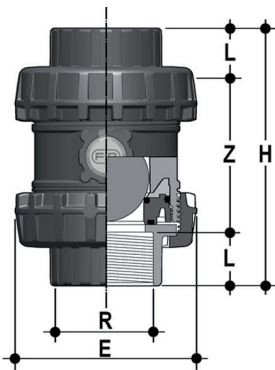

SXENV

Easyfit ball check valve with female ends, NPT thread

R	DN	PN	E	H	L	Z	g	EPDM code	FKM code
2" 1/2	65	16	157	211	33,2	144,6	2605	SXENV212E	SXENV212F
3"	80	16	174	248	35,5	177	3300	SXENV300E	SXENV300F
4"	100	16	212	283	37,6	207,8	5770	SXENV400E	SXENV400F

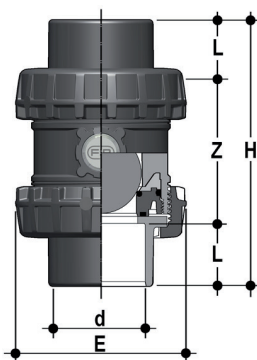

SXEJV

Easyfit ball check valve with female ends, NPT thread

d	DN	PN	E	H	L	Z	g	EPDM code	FKM code
2" 1/2	65	16	157	243	61	121	2605	SXEJV212E	SXEJV212F
3"	80	16	174	272	64,5	143	3300	SXEJV300E	SXEJV300F
4"	100	16	212	332	84	164	5770	SXEJV400E	SXEJV400F

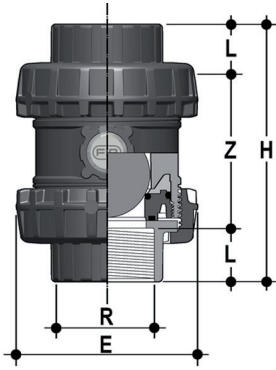

SXEGV

Easyfit ball check valve with female ends, JIS thread

R	DN	PN	E	H	L	Z	g	EPDM code	FKM code
2" 1/2	65	16	157	211	35	141	2605	SXEGV212E	SXEGV212F
3"	80	16	174	248	40	168	3300	SXEGV300E	SXEGV300F
4"	100	16	212	283	45	193	5770	SXEGV400E	SXEGV400F

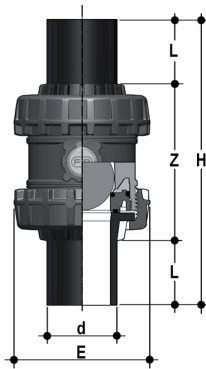

SXEBEV

Easyfit ball check valve with PE100 SDR 11 male end connectors for butt welding or electrofusion (CVDE)

d	DN	PN	E	H	L	Z	g	EPDM code	FKM code
75	65	16	157	331	71	189	2605	SXEBEV075E	SXEBEV075F
90	80	10	174	367	88	191	3300	SXEBEV090E	SXEBEV090F
110	100	10	212	407	92	223	5770	SXEBEV110E	SXEBEV110F

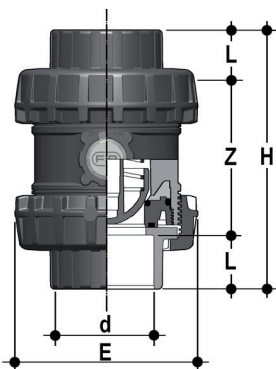

SSEIV - A316 Spring

Easyfit spring check valve with female ends for solvent welding, metric series

d	DN	PN	E	H	L	Z	g	EPDM code	FKM code
75	65	16	157	211	44	123	2480	SSEIV075E	SSEIV075F
90	80	16	174	248	51	146	3090	SSEIV090E	SSEIV090F
110	100	16	212	283	61	161	5370	SSEIV110E	SSEIV110F

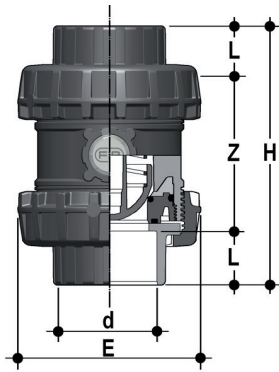

SSEIV - A316/PTFE encapsulated Spring

Easyfit spring check valve with female ends for solvent welding, metric series

d	DN	PN	E	H	L	Z	g	EPDM code	FKM code
75	65	16	157	211	44	123	2480	SSEIV075EOP	SSEIV075FOP
90	80	16	174	248	51	146	3090	SSEIV090EOP	SSEIV090FOP
110	100	16	212	283	61	161	5370	SSEIV110EOP	SSEIV110FOP

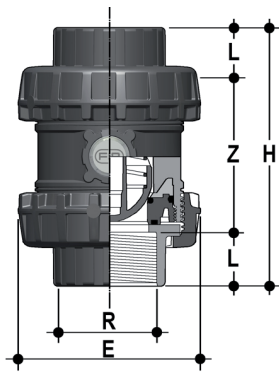

SSEFV - A316 Spring

Easyfit spring check valve with female ends for solvent welding, metric series

R	DN	PN	E	H	L	Z	g	EPDM code	FKM code
2" 1/2	65	16	157	211	30,2	150,6	2480	SSEFV212E	SSEFV212F
3"	80	16	174	248	33,3	181,4	3090	SSEFV300E	SSEFV300F
4"	100	16	212	283	39,3	204,4	5370	SSEFV400E	SSEFV400F

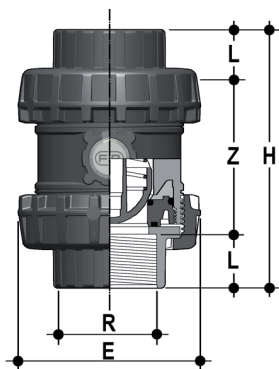

SSEFV - A316/PTFE encapsulated Spring

Easyfit spring check valve with BSP threaded female ends

R	DN	PN	E	H	L	Z	g	EPDM code	FKM code
2" 1/2	65	16	157	211	30,2	150,6	2480	SSEFV212EOP	SSEFV212FOP
3"	80	16	174	248	33,3	181,4	3090	SSEFV300EOP	SSEFV300FOP
4"	100	16	212	283	39,3	204,4	5370	SSEFV400EOP	SSEFV400FOP

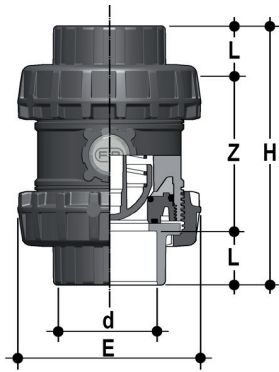

SSELV - A316 Spring

Easyfit spring check valve with female ends for solvent welding, BS series

d	DN	PN	E	H	L	Z	g	EPDM code	FKM code
2" 1/2	65	16	157	211	44	123	2480	SSEIV075E	SSEIV075F
3"	80	16	174	248	51	146	3090	SSELV300E	SSELV300F
4"	100	16	212	283	63	157	5370	SSELV400E	SSELV400F

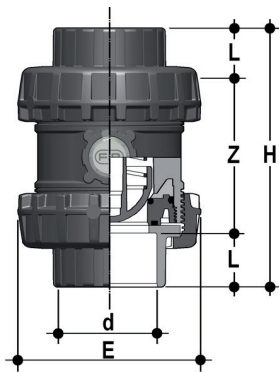

SSELV - A316/PTFE encapsulated Spring

Easyfit spring check valve with female ends for solvent welding, BS series

d	DN	PN	E	H	L	Z	g	EPDM code	FKM code
2" 1/2	65	16	157	211	44	123	2480	SSEIV075EOP	SSEIV075FOP
3"	80	16	174	248	51	146	3090	SSELV300EOP	SSELV300FOP
4"	100	16	212	283	63	157	5370	SSELV400EOP	SSELV400FOP

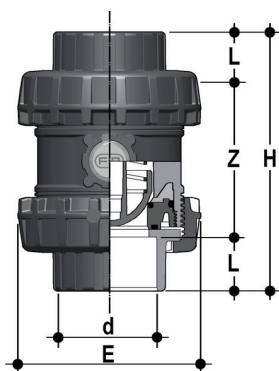

SSEAV - A316 Spring

Easyfit spring check valve with female ends for solvent welding, ASTM series

d	DN	PN	E	H	L	Z	g	EPDM code	FKM code
2" 1/2	65	16	157	211	44,5	122	2480	SSEAV212E	SSEAV212F
3"	80	16	174	248	48	152	3090	SSEAV300E	SSEAV300F
4"	100	16	212	283	57,5	168	5370	SSEAV400E	SSEAV400F

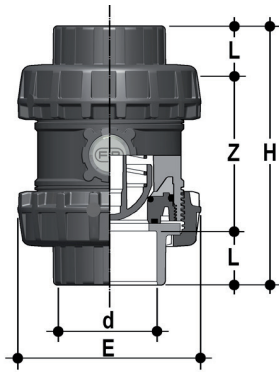

SSEAV - A316/PTFE encapsulated Spring

Easyfit spring check valve with female ends for solvent welding, ASTM series

d	DN	PN	E	H	L	Z	g	EPDM code	FKM code
2" 1/2	65	16	157	211	44,5	122	2480	SSEAV212EOP	SSEAV212FOP
3"	80	16	174	248	48	152	3090	SSEAV300EOP	SSEAV300FOP
4"	100	16	212	283	57,5	168	5370	SSEAV400EOP	SSEAV400FOP

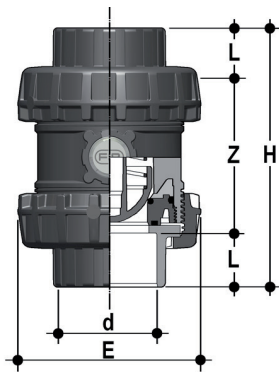

SSEIV

Easyfit spring check valve with female ends for solvent welding, metric series

d	DN	PN	E	H	L	Z	g	EPDM code	FKM code
75	65	16	157	211	44	123	2480	SSEIV075E	SSEIV075F
90	80	16	174	248	51	146	3090	SSEIV090E	SSEIV090F
110	100	16	212	283	61	161	5370	SSEIV110E	SSEIV110F

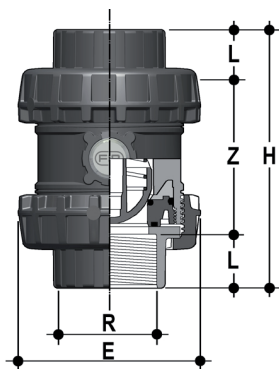

SSEFV

Easyfit spring check valve with female ends for solvent welding, metric series

R	DN	PN	E	H	L	Z	g	EPDM code	FKM code
2" 1/2	65	16	157	211	30,2	150,6	2480	SSEFV212E	SSEFV212F
3"	80	16	174	248	33,3	181,4	3090	SSEFV300E	SSEFV300F
4"	100	16	212	283	39,3	204,4	5370	SSEFV400E	SSEFV400F

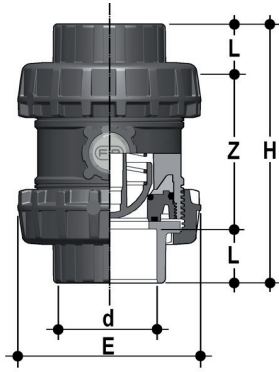

SSELV

Easyfit spring check valve with female ends for solvent welding, BS series

d	DN	PN	E	H	L	Z	g	EPDM code	FKM code
2" 1/2	65	16	157	211	44	123	2480	SSEIV075E	SSEIV075F
3"	80	16	174	248	51	146	3090	SSELV300E	SSELV300F
4"	100	16	212	283	63	157	5370	SSELV400E	SSELV400F

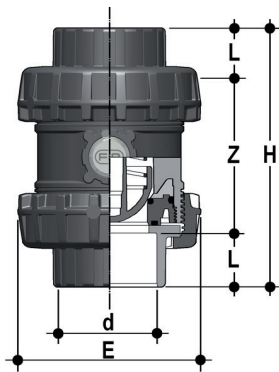

SSEAV

Easyfit spring check valve with female ends for solvent welding, ASTM series

d	DN	PN	E	H	L	Z	g	EPDM code	FKM code
2" 1/2	65	16	157	211	44,5	122	2480	SSEAV212E	SSEAV212F
3"	80	16	174	248	48	152	3090	SSEAV300E	SSEAV300F
4"	100	16	212	283	57,5	168	5370	SSEAV400E	SSEAV400F

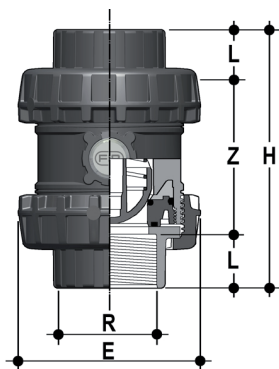

SSENV

Easyfit spring check valve with female ends, NPT thread

R	DN	PN	E	H	L	Z	g	EPDM code	FKM code
2" 1/2	65	16	157	211	33,2	144,6	2480	SSENV212E	SSENV212F
3"	80	16	174	248	35,5	177	3090	SSENV300E	SSENV300F
4"	100	16	212	283	37,6	207,8	5370	SSENV400E	SSENV400F

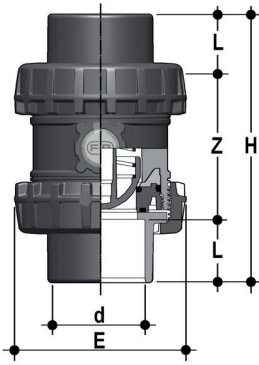

SSEJV

Easyfit spring check valve with female ends for solvent welding, JIS series

d	DN	PN	E	H	L	Z	g	EPDM code	FKM code
2" 1/2	65	16	157	243	61	121	2480	SSEJV212E	SSEJV212F
3"	80	16	174	272	64,5	143	3090	SSEJV300E	SSEJV300F
4"	100	16	212	332	84	164	5370	SSEJV400E	SSEJV400F

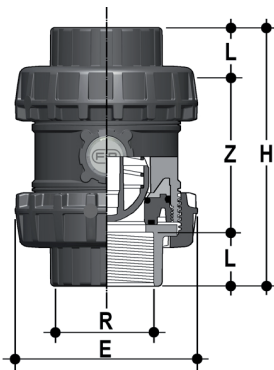

SSEGV

Easyfit spring check valve with female ends, JIS thread

R	DN	PN	E	H	L	Z	g	EPDM code	FKM code
2" 1/2	65	16	157	211	35	141	2480	SSEGV212E	SSEGV212F
3"	80	16	174	248	40	168	3090	SSEGV300E	SSEGV300F
4"	100	16	212	283	45	193	5370	SSEGV400E	SSEGV400F

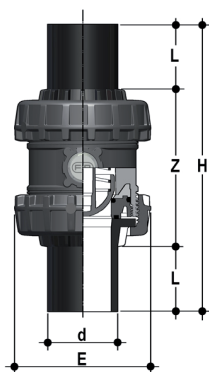

SSEBEV - A316 Spring

Easyfit spring check valve with PE100 SDR 11 male end connectors for butt welding or electrofusion (CVDE)

d	DN	PN	E	H	L	Z	g	EPDM code	FKM code
75	65	16	157	331	71	189	2480	SSEBEV075E	SSEBEV075F
90	80	10	174	367	88	191	3090	SSEBEV090E	SSEBEV090F
110	100	10	212	407	92	223	5370	SSEBEV110E	SSEBEV110F

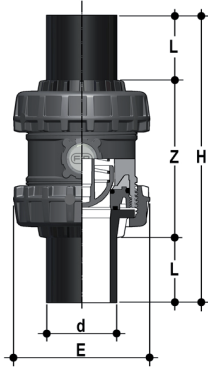

SSEBEV - A316/PTFE encapsulated Spring

Easyfit spring check valve with PE100 SDR 11 male end connectors for butt welding or electrofusion (CVDE)

d	DN	PN	E	H	L	Z	g	EPDM code	FKM code
75	65	16	157	331	71	189	2480	SSEBEV075EOP	SSEBEV075FOP
90	80	10	174	367	88	191	3090	SSEBEV090EOP	SSEBEV090FOP
110	100	10	212	407	92	223	5370	SSEBEV110EOP	SSEBEV110FOP

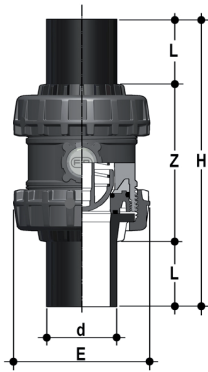

SSEBEV

Easyfit spring check valve with PE100 SDR 11 male end connectors for butt welding or electrofusion (CVDE)

d	DN	PN	E	H	L	Z	g	EPDM code	FKM code
75	65	16	157	331	71	189	2480	SSEBEV075E	SSEBEV075F
90	80	10	174	367	88	191	3090	SSEBEV090E	SSEBEV090F
110	100	10	212	407	92	223	5370	SSEBEV110E	SSEBEV110F

ACCESSORIES

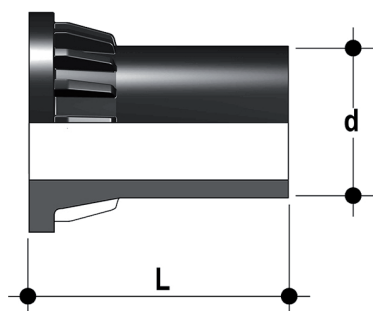

CVDE

Long spigot PE100 end connectors for joints with electrofusion fittings or for butt welding

d	DN	PN	L	SDR	Code
75	65	16	111	11	CVDE11075
90	80	10	118	11	CVDE11090VXE
110	100	10	127	11	CVDE11110VXE

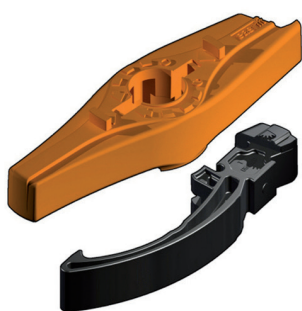

EASYFIT HANDLE DN 65÷100

Easyfit multifunctional handle for union nut tightening SXE-SSE DN 65÷100

d	DN	Code
75	65	HSVXE075
90	80	HSVXE090
110	100	HSVXE110



LSE

Customisation and label printing set for Easyfit handle made up of precut adhesive sheets and software for guided label creation.

d	DN	SXE - SSE code
75	65	LSE063
90	80	LSE063
110	100	LSE063

CUSTOMISATION



SXE and SSE DN 65÷100 Easyfit valves are equipped with a customisable Labelling System.

This system lets you create special labels to affix to the valve body. This makes it extremely easy to apply company logos, identification serial numbers or service indications such as, for example, the valve function in the system, the transported fluid, but also specific information for customer service, such as the customer name or installation date or location on the valves.

The specific LCE module is a standard supply and is made up of a rigid transparent water-resistant PVC plug and white tag holder made of the same material, one side of which bears the FIP logo.

The holder, inserted in the plug, can be removed and, once overturned, used for customisation by applying labels printed with the software supplied with the LSE set.

Proceed as follows to apply the label on the valve:

- 1) Remove the transparent plug from the housing on the valve body.
- 2) Extract the tag holder from the transparent plug.
- 3) Apply the adhesive label on the holder to align the profiles matching the tab position.
- 4) Reinsert the tag holder in the transparent plug so that the label is protected against the elements.
- 5) Replace the transparent plug in its seat on the valve body.

COMPONENTS

EXPLODED VIEW

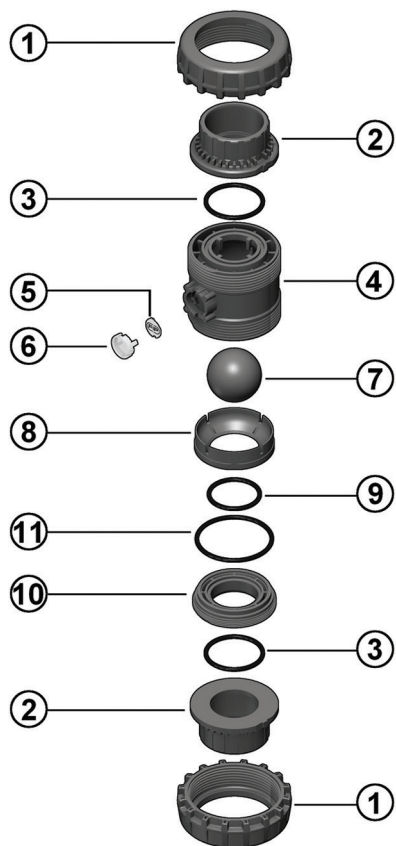

SXE

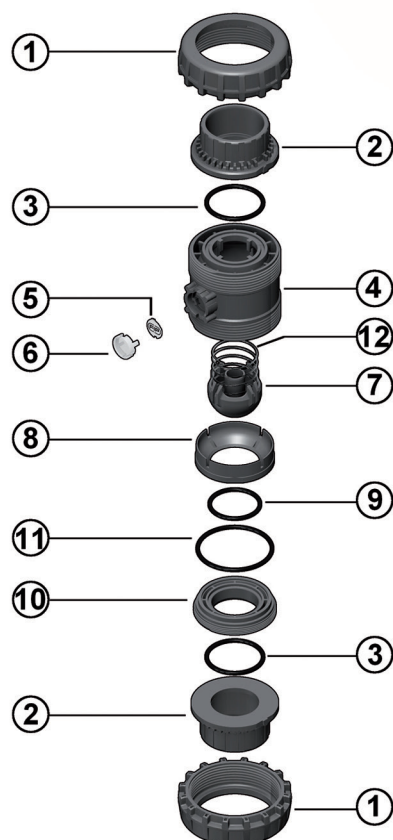

SSE

- 1** Union nut (PVC-U - 2)
- 2** End connector (PVC-U - 2)
- 3** Socket seal O-Ring (EPDM, FKM - 2)
- 4** Body (PVC-U - 1)
- 5** Tag holder (PVC - 1)
- 6** Transparent protection plug (PVC - 1)

- 7** Ball (PVC-U - 1)
- SXE**
- 7** Shutter (PVC-U - 1)
- SSE**
- 8** Gland packing ring (PVC-U - 1)
- 9** Ball seat O-Ring (EPDM, FKM - 1)
- SXE**

- 9** Shutter gasket (EPDM, FKM - 1)
- SSE**
- 10** Ball seat carrier (PVC-U - 1)
- SXE**
- 10** Shutter seat O-ring (PVC-U - 1)
- SSE**
- 11** Radial seal O-Ring (EPDM,FKM - 1)
- 12** Spring (STAINLESS steel* - 1)

* Also available made of A316 PTFE encapsulated
The component material and quantity supplied are indicated in the parentheses.

DISASSEMBLY

SXE

SXE valves do not require maintenance in normal operating conditions. In the event of leaks or wear, before performing maintenance, cut-off fluid upstream from the valve and make sure it is de-pressurised (downstream drain if necessary).

- 1) Fully drain residual liquid that could be aggressive for the operator and, if possible, circulate water to internally clean the valve.
- 2) For easy union nut tightening in assembly, use the Easyfit multifunctional handle (supplied as an accessory).
- 3) Unscrew the ball seat carrier (10) with the Easyfit multifunctional handle: introduce the two protrusion on the top of the handle in the grooves in the carrier (10) and unscrew, extracting it counter-clockwise.
- 4) Remove all internal components.

SSE

In the event of leaks or wear, before performing maintenance, cut-off fluid upstream from the valve and make sure it is de-pressurised (downstream drain if necessary).

- 1) Fully drain residual liquid that could be aggressive for the operator and, if possible, circulate water to internally clean the valve.
- 2) For easy union nut tightening in assembly, use the Easyfit multifunctional handle (supplied as an accessory).
- 3) Unscrew the ball seat carrier (10) with the Easyfit multifunctional handle: introduce the two protrusion on the top of the handle in the grooves in the carrier (10) and unscrew, extracting it counter-clockwise.
- 4) Remove all internal components.

ASSEMBLY

SXE

- 1) Reconstruct the valve following the exploded view on the previous page.
- 2) Tighten the ball seat carrier (10) using the Easyfit multifunctional handle. This ensures optimal valve installation and operations (fig. 3).
- 3) Position the valve between the end connectors (2) and tighten the union nuts clockwise (1) using the Easyfit multifunctional handle (fig. 7) being sure the socket seal O-ring (3) does not exit the seats.

SSE

- 1) Reconstruct the valve following the exploded view on the previous page.
- 2) Tighten the ball seat carrier (10) using the Easyfit multifunctional handle. This ensures optimal valve installation and operations (fig. 3).
- 3) Position the valve between the end connectors (2) and tighten the union nuts clockwise (1) using the Easyfit multifunctional handle (fig. 7) being sure the socket seal O-ring (3) does not exit the seats.



Note: during assembly operations, it is advisable to lubricate the rubber seals. Mineral oils are not recommended for this task as they react aggressively with EPDM rubber.

Fig. 1



Fig. 2



Fig. 3



Fig. 4



INSTALLATION

SXE and SSE valves can be installed both vertically (upward flow) and horizontally (SXE with minimum 0.2 bar back pressure).

Before proceeding with installation, please follow these instructions carefully:

- 1) Check that the pipes to be connected to the valve are aligned in order to avoid mechanical stress on the threaded joints.
- 2) Unscrew the union nuts (1) from the body (4) and insert them in the pipe segments.
- 3) Solvent weld or screw the end connectors (2) onto the pipe segments.
- 4) Position the valve body between the end connectors (fig. 1).
- 5) Place the union nuts on the valve body and start tightening manually clockwise until they are hard to turn. Do not use wrenches or other tools that can damage the union nut surface (fig. 2).
- 6) For easy union nut tightening in assembly, use the Easyfit multifunctional handle (supplied as an accessory).
- 7) Extract the hooked insert in the handle (fig. 5) overturn it and fit it in the seat on the lower part of the handle (fig. 6).
- 8) Fit the tool on the external union nut profile until firmly and safely secured that allows for adequate torque without damaging the union nut in any way (fig. 7).
- 9) Repeat point 7 for the other union nut.
- 10) When tightened, remove the hooked insert and replace it in its seat in the handle.
- 11) If necessary, support the pipe with FIP pipe clip model ZIKM and DSM distance plates.

WARNINGS

Do not use compressed air or other gases to test thermoplastic lines. Always avoid sudden closing manoeuvres and protect the valve against accidental manoeuvres.

Leave a straight section of pipe of length equal to 5 times the nominal diameter before and after the valve.

Fig. 5



Fig. 6

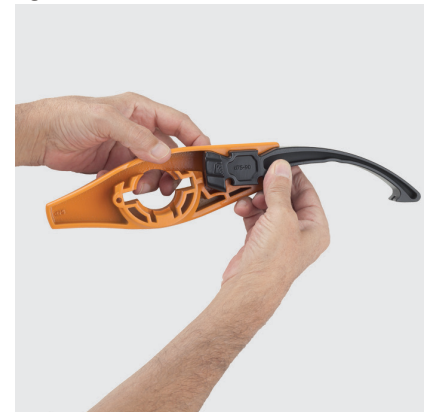

Fig. 7

