

VKD DN 65÷100

DUAL BLOCK® 2-way ball valve



VKD DN 65÷100

FIP has developed a VKD DUAL BLOCK® ball valve to introduce a high reference standard in thermoplastic valve design. VKD is a True Union ball valve that meets the most stringent needs required by industrial applications. This valve is also equipped with a customisable Labelling System.



DUAL BLOCK® 2-WAY BALL VALVE

- Connection system for solvent weld, threaded and flanged joints
- Patented **SEAT STOP®** ball carrier system that lets you micro-adjust seals and minimise axial force effects
- Easy radial dismantling allowing quick replacement of O-rings and ball seats without any need for tools
- **PN16 True Union valve body** made for rigid PVC-U injection moulding equipped with built-in bores for actuation. ISO 9393 compliant test requisites
- Option of dismantling downstream pipes with the valve in the closed position
- **Full bore ball** with high surface finish
- **Integrated bracket** for valve anchoring
- Possibility of installing a manual reducer or pneumatic and/or electric actuators by applying an ISO standard bore PP-GR flange
- **STAINLESS steel co-moulded stem**, with square section as per ISO 5211
- Possibility to have handle with integrated LSQT limit micro switch, even as a retrofit in existing installations

Technical specifications

Construction	2-way True Union ball valve with locked carrier and union nuts.
Size range	DN 65 ÷ 100
Nominal pressure	PN 16 with water at 20° C
Temperature range	0 °C ÷ 60 °C
Coupling standards	<p>Solvent welding: EN ISO 1452, EN ISO 15493, BS 4346-1, , NF T54-028, ASTM D 2467, JIS K 6743. Pipe coupling as EN ISO 1452, EN ISO 15493, DIN 8062, NF T54-016, ASTM D 1785, JIS K 6741.</p> <p>Thread:ISO 228-1, EN10226-1-2, ASTM D 2467, JIS B 0203.</p> <p>Flanging system: ISO 7005-1, EN ISO 1452, EN ISO 15493 EN 588-1, EN 1092-1, ANSI B.16.5 cl.150, JIS B 2220.</p>
Reference standards	<p>Construction criteria: EN ISO 16135, EN ISO 1452, EN ISO 15493</p> <p>Test methods and requirements: ISO 9393</p> <p>Installation criteria: DVS 2204, DVS 2221, UNI 11242</p> <p>Actuator couplings: ISO 5211</p>
Valve material	PVC-U
Seal material	EPDM, FKM; PTFE (ball seats)
Control options	Manual control; electric actuator; pneumatic actuator

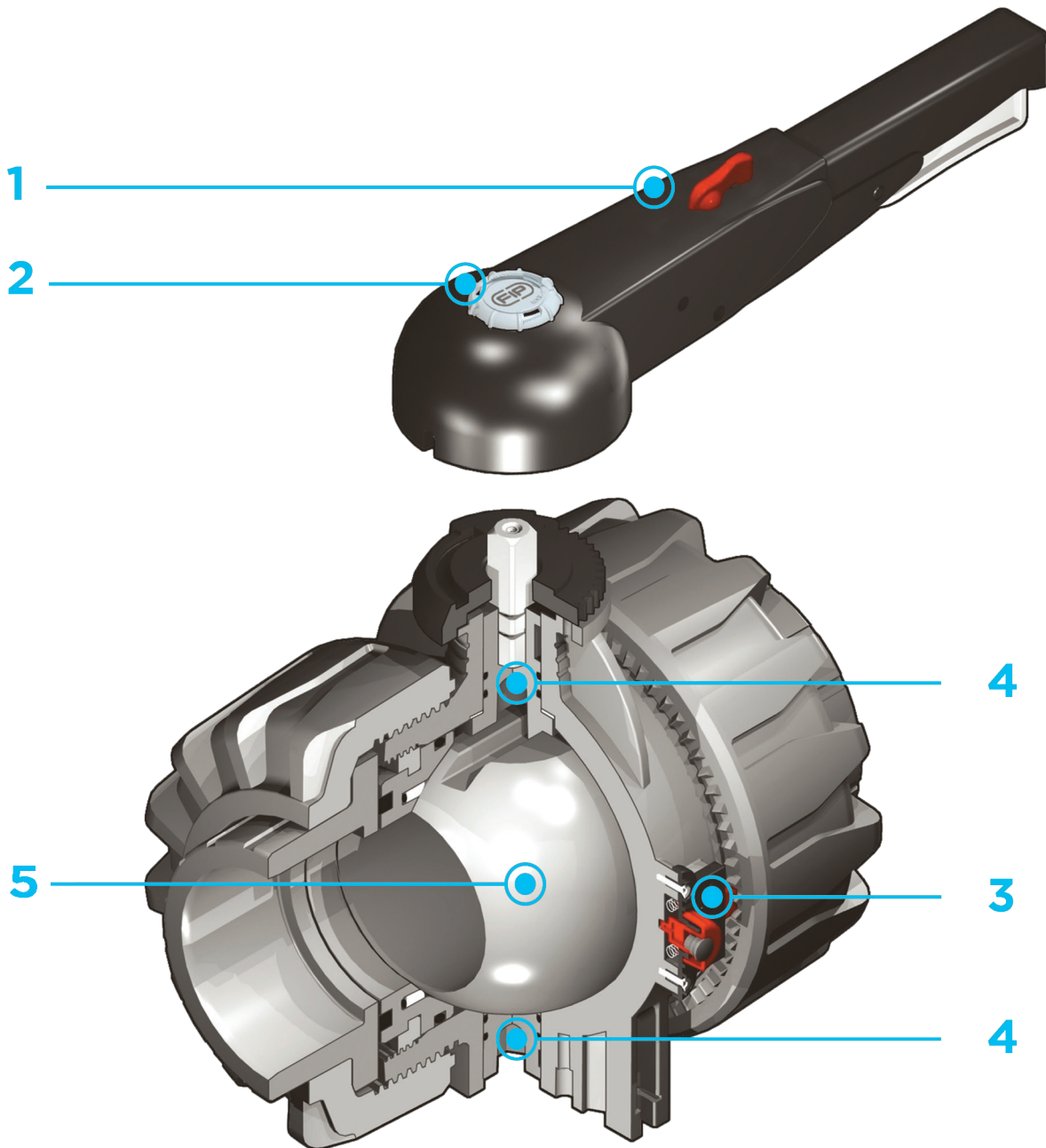

1 HIPVC ergonomic multifunctional handle for quick operation, **lock and graduated adjustment in 10 positions**. Possibility of inhibiting rotation with a lock

2 Customisable Labelling System: LCE module made of a transparent protection plug and **customisable tag holder** using the LSE set

(available as accessory). The customisation lets you identify the valve on the system according to specific needs

3 **DUAL BLOCK®** patented lock system that ensures union nut tightening hold even in severe conditions such as vibrations or heat dilation

4 **Double stem** with double O-Rings for ball centring and operating torque reduction

5 Machined high surface finish ball that guarantees a smooth operation and increased reliability

TECHNICAL DATA

PRESSURE VARIATION ACCORDING TO TEMPERATURE

For water and harmless fluids to which the material is classified as CHEMICALLY RESISTANT. In other cases, a reduction of the nominal PN pressure is required (25 years with safety factor).



PRESSURE DROP GRAPH

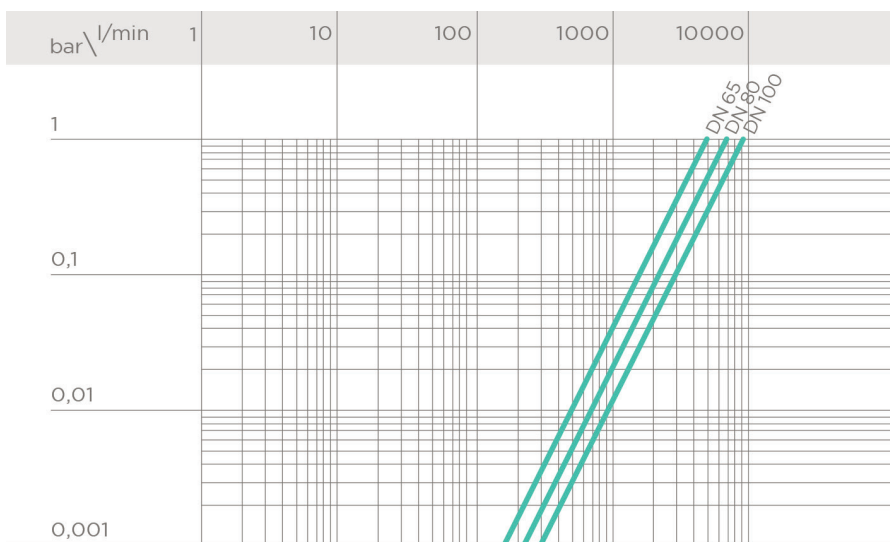

K_v100 FLOW COEFFICIENT

The K_v100 flow coefficient is the Q flow rate of litres per minute of water at a temperature of 20°C that will generate Δp= 1 bar pressure drop at a certain valve position. The Kv100 values shown in the table are calculated with the valve completely open.

DN	65	80	100
K _v 100 l/min	5250	7100	9500

OPERATING TORQUE AT MAXIMUM WORKING PRESSURE

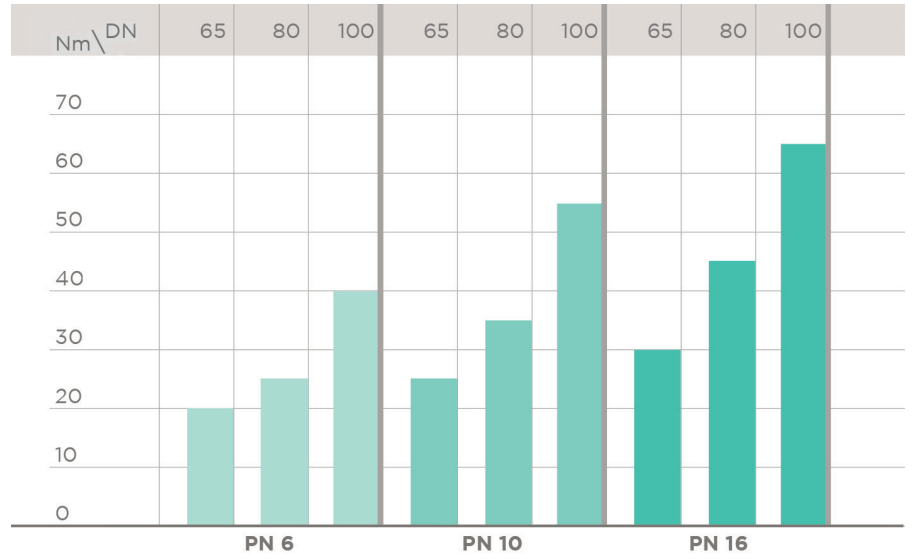

The information in this leaflet is provided in good faith. No liability will be accepted concerning technical data that is not directly covered by recognised international standards. FIP reserves the right to carry out any modification. Products must be installed and maintained by qualified personnel.

DIMENSIONS

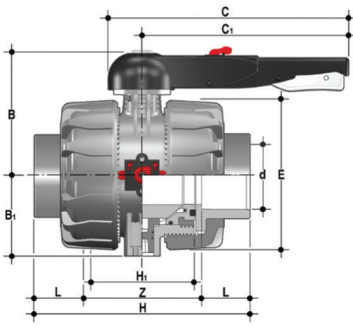

VKDIV

DUAL BLOCK® 2-way ball valve with female ends, metric series

d	DN	PN	B	B ₁	C	C ₁	E	H	H ₁	L	Z	g	EPDM code	FKM code
75	65	16	164	87	225	175	164	235	133	44	147	4380	VKDIV075E	VKDIV075F
90	80	16	177	105	327	272	203	270	149	51	168	7200	VKDIV090E	VKDIV090F
110	100	16	195	129	385	330	238	308	167	61	186	11141	VKDIV110E	VKDIV110F

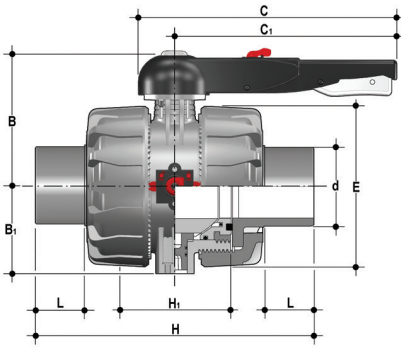

VKDDV

DUAL BLOCK® 2-way ball valve with male ends for solvent welding, metric series

d	DN	PN	B	B ₁	C	C ₁	E	H	H ₁	L	g	EPDM code	FKM code
75	65	16	164	87	225	175	164	284	133	44	4420	VKDDV075E	VKDDV075F
90	80	16	177	105	327	272	203	300	149	51	6930	VKDDV090E	VKDDV090F
110	100	16	195	129	385	330	238	340	167	61	10950	VKDDV110E	VKDDV110F

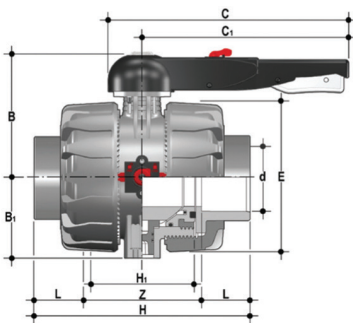

VKDLV

DUAL BLOCK® 2-way ball valve with female ends for solvent welding, BS series

d	DN	PN	B	B ₁	C	C ₁	E	H	H ₁	L	Z	g	EPDM code	FKM code
2" 1/2	65	16	164	87	225	175	164	235	133	44	147	4380	VKDIV075E	VKDIV075F
3"	80	16	177	105	327	272	203	270	149	51	168	7250	VKDLV300E	VKDLV300F
4"	100	16	195	129	385	330	238	308	167	63	182	10995	VKDLV400E	VKDLV400F

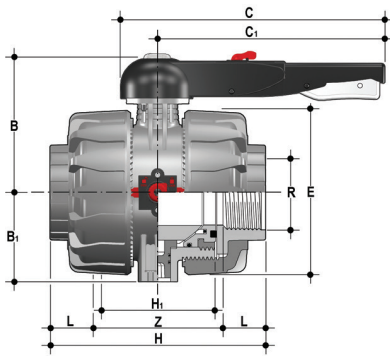

VKDFV

DUAL BLOCK® 2-way ball valve with BSP threaded female ends

R	DN	PN	B	B ₁	C	C ₁	E	H	H ₁	L	Z	g	EPDM code	FKM code
2" 1/2	65	16	164	87	225	175	164	235	133	30	175	4395	VKDFV212E	VKDFV212F
3"	80	16	177	105	327	272	203	270	149	34	203	7260	VKDFV300E	VKDFV300F
4"	100	16	195	129	385	330	238	308	167	40	229	11100	VKDFV400E	VKDFV400F

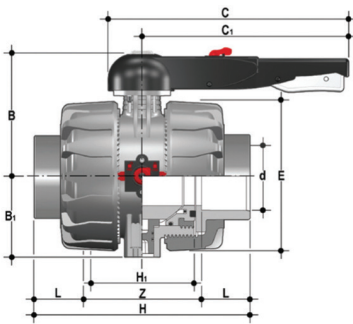

VKDAV

DUAL BLOCK® 2-way ball valve with female ends for solvent welding, ASTM series

d	DN	PN	B	B ₁	C	C ₁	E	H	H ₁	L	Z	g	EPDM code	FKM code
2" 1/2	65	16	164	87	225	175	164	235	133	44,5	146	4390	VKDAV212E	VKDAV212F
3"	80	16	177	105	327	272	203	270	149	48	174	7210	VKDAV300E	VKDAV300F
4"	100	16	195	129	385	330	238	308	167	57,5	193	11065	VKDAV400E	VKDAV400F

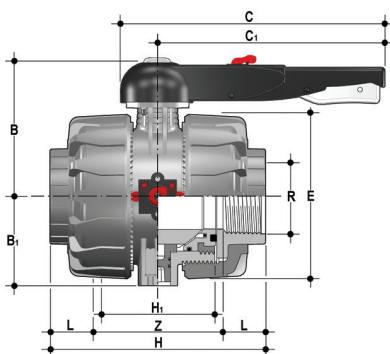

VKDNV

DUAL BLOCK® 2-way ball valve with female ends, NPT thread

R	DN	PN	B	B ₁	C	C ₁	E	H	H ₁	L	Z	g	EPDM code	FKM code
2" 1/2	65	16	164	87	225	175	164	235	133	33,2	168,6	4395	VKDNV212E	VKDNV212F
3"	80	16	177	105	327	272	203	270	149	35,5	199	7260	VKDNV300E	VKDNV300F
4"	100	16	195	129	385	330	238	308	167	37,6	232,8	11100	VKDNV400E	VKDNV400F

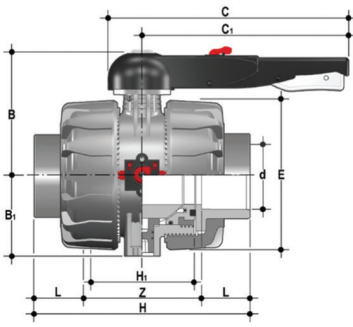

VKDJV

DUAL BLOCK® 2-way ball valve with female ends for solvent welding, JIS series

d	DN	PN	B	B ₁	C	C ₁	E	H	H ₁	L	Z	g	EPDM code	FKM code
2" 1/2	65	16	164	87	225	175	164	267	133	61	145	4435	VKDJV212E	VKDJV212F
3"	80	16	177	105	327	272	203	294	149	64,5	165	7250	VKDJV300E	VKDJV300F
4"	100	16	195	129	385	330	238	370	167	84	202	11580	VKDJV400E	VKDJV400F

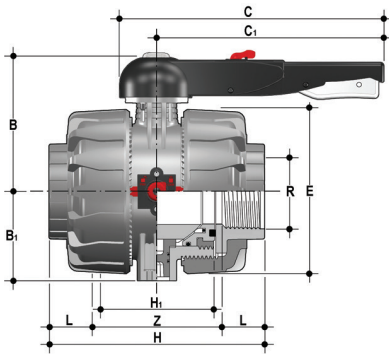

VKDGV

DUAL BLOCK® 2-way ball valve with female ends, JIS thread

R	DN	PN	B	B ₁	C	C ₁	E	H	H ₁	L	Z	g	EPDM code	FKM code
2" 1/2	65	16	164	87	225	175	164	235	133	35	165	4400	VKDGv212E	VKDGv212F
3"	80	16	177	105	327	272	203	270	149	40	190	7270	VKDGv300E	VKDGv300F
4"	100	16	195	129	385	330	238	308	167	45	218	11115	VKDGv400E	VKDGv400F

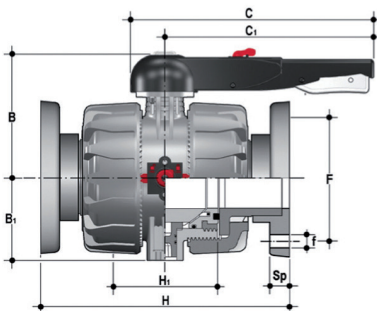

VKDOV

DUAL BLOCK® 2-way ball valve with fixed flanges, drilled PN10/16. Face to face according to EN 558-1

d	DN	PN	B	B ₁	C	C ₁	F	f	H	H ₁	Sp	U	g	EPDM code	FKM code
75	65	16	164	87	327	175	145	17	290	133	21	4	6610	VKDOV075E	VKDOV075F
90	80	16	177	105	327	272	160	17	310	149	21,5	8	9330	VKDOV090E	VKDOV090F
110	100	16	195	129	385	330	180	17	350	167	21,5	8	13815	VKDOV110E	VKDOV110F

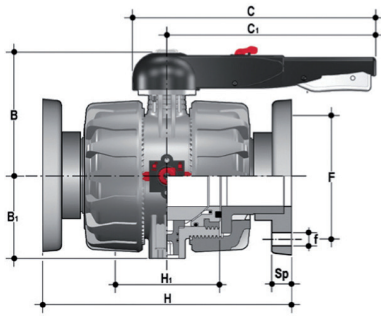

VKDOAV

DUAL BLOCK® 2-way ball valve with fixed flanges, drilled ANSI B.16.5 cl.150 #FF. Face to face according to EN 558-1

d	DN	PN	B	B ₁	C	C ₁	F	f	H	H ₁	Sp	U	g	EPDM code	FKM code
2" 1/2	65	16	164	87	327	175	139,7	18	290	133	21	4	6610	VKDOV075E	VKDOV075F
3"	80	16	177	105	327	272	152,4	18	310	149	21,5	8	9330	VKDOV090E	VKDOV090F
4"	100	16	195	129	385	330	190,5	18	350	167	21,5	8	13815	VKDOV110E	VKDOV110F

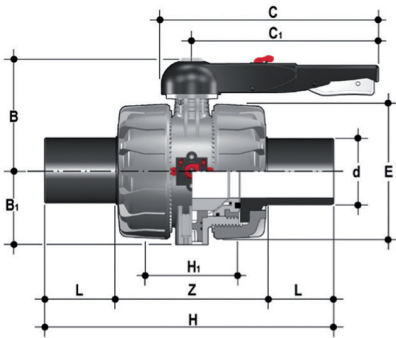

VKDBEV

DUAL BLOCK® 2-way valve with PE100 SDR 11 male end connectors for butt welding or electrofusion (CVDE)

d	DN	PN	B	B ₁	C	C ₁	E	H	H ₁	L	Z	g	EPDM code	FKM code
75	65	16	164	87	225	175	162	356	133	71	214	4400	VKDBEV075E	VKDBEV075F
90	80	16	177	105	327	272	202	390	149	88	214	7100	VKDBEV090E	VKDBEV090F
110	100	16	195	129	385	330	236	431	167	92	247	10800	VKDBEV110E	VKDBEV110F

ACCESSORIES

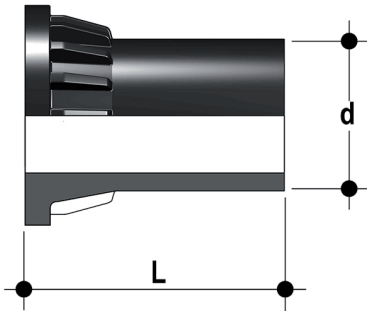

CVDE

Long spigot PE100 end connectors for joints with electrofusion fittings or for butt welding

d	DN	PN	L	SDR	Code
75	65	16	111	11	CVDE11075
90	80	16	118	11	CVDE11090
110	100	16	132	11	CVDE11110



LSE

Customisation and label printing set for Easyfit handle made up of precut adhesive sheets and software for guided label creation.

d	DN	VKD* code
75	65	LSE040
90	80	LSE040
110	100	LSE040

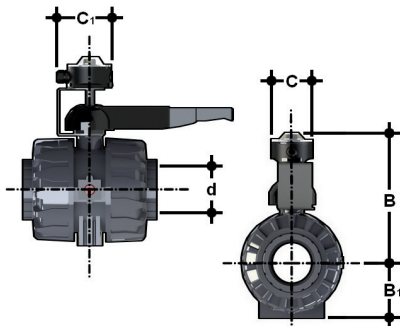

LS Quick Kit

The Limit Switch Quick Kit allows the fast and secure installation of the FIP LSQT to the VKD valves. The body is in PP-GR and the handle is in stainless steel AISI 316. The handle block at 0° and 90° is also available by default (hole diameter 6.5 mm). The kit can be assembled on the valve even if already installed on the system. For technical data of the LSQT box see FIP actuated valves catalogue.

d	DN	B	B ₁	C	C ₁	Code
75	65	275	87	103	126,9	LSQKIT75160
90	80	286,7	105	103	126,9	LSQKIT75160
110	100	305,5	129	103	126,9	LSQKIT75160

ACTUATOR MOUNTING FLANGE

The valve can be equipped with pneumatic or electric standard actuators and handwheel reduces for heavy-duty operations, using the PP-GR module reproducing the drilling pattern foreseen by ISO 5211 F07.

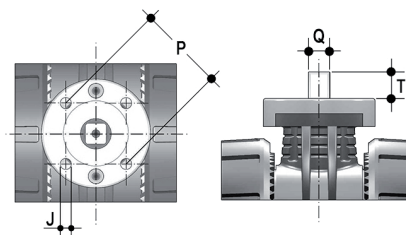

d	DN	P x J	T	Q
75	65	F07 x 9	16	14
90	80	F07 x 9	16	14
110	100	F07 x 9	19	17

FASTENING AND SUPPORTING



All valves, whether manual or actuated, must be adequately supported in many applications.

The VKD DN 65÷100 valve series is therefore ready to be equipped with threaded supporting brackets (optional) that permits direct anchoring on the valve body without the need of other components.

Using standard threaded nuts (not included) made of STAINLESS steel, you can anchor the valve on 4 fastening points.

d	DN	J	f	l	l1	l2
75	65	M6	6,3	17,4	90	51,8
90	80	M6	8,4	21,2	112,6	63
110	100	M8	8,4	21,2	137	67

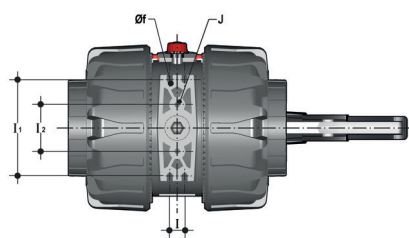

CUSTOMISATION

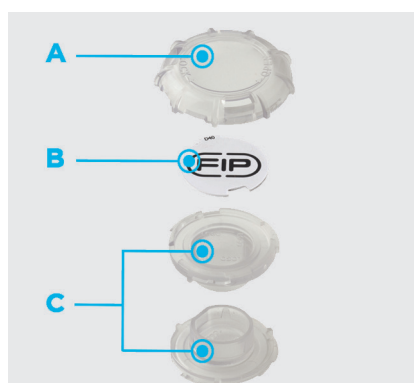

The VKD DN 65-100 valve is equipped with the customisable Labelling System. This system lets you create special labels to insert in the handle. This makes it extremely easy to apply company logos, identification serial numbers or service indications such as, for example, the valve function in the system, the transported fluid, but also specific information for customer service, such as the customer name or installation date or location on the valves.

The specific LCE module is a standard supply and is made up of a rigid transparent water-resistant PVC plug (A-C) and white tag holder (B) made of the same material, one side of which bears the FIP logo.

The holder, inserted in the plug, can be removed and, once overturned, used for customisation by applying labels printed with the software supplied with the LSE set.

Proceed as follows to apply the label on the valve:

- 1) Remove the upper part of the transparent plug (A) rotating it counter-clockwise as indicated by the "Open" label on the plug and remove it.
- 2) Extract the tag holder from its housing on the lower part of the plug (C)
- 3) Apply the adhesive label on the tag holder (B) to align the profiles matching the tab position.
- 4) Reinsert the tag holder in its housing at the bottom of the plug
- 5) Reposition the top of the plug in the housing rotating it clockwise; this way the label is protected against the elements.

COMPONENTS

EXPLODED VIEW

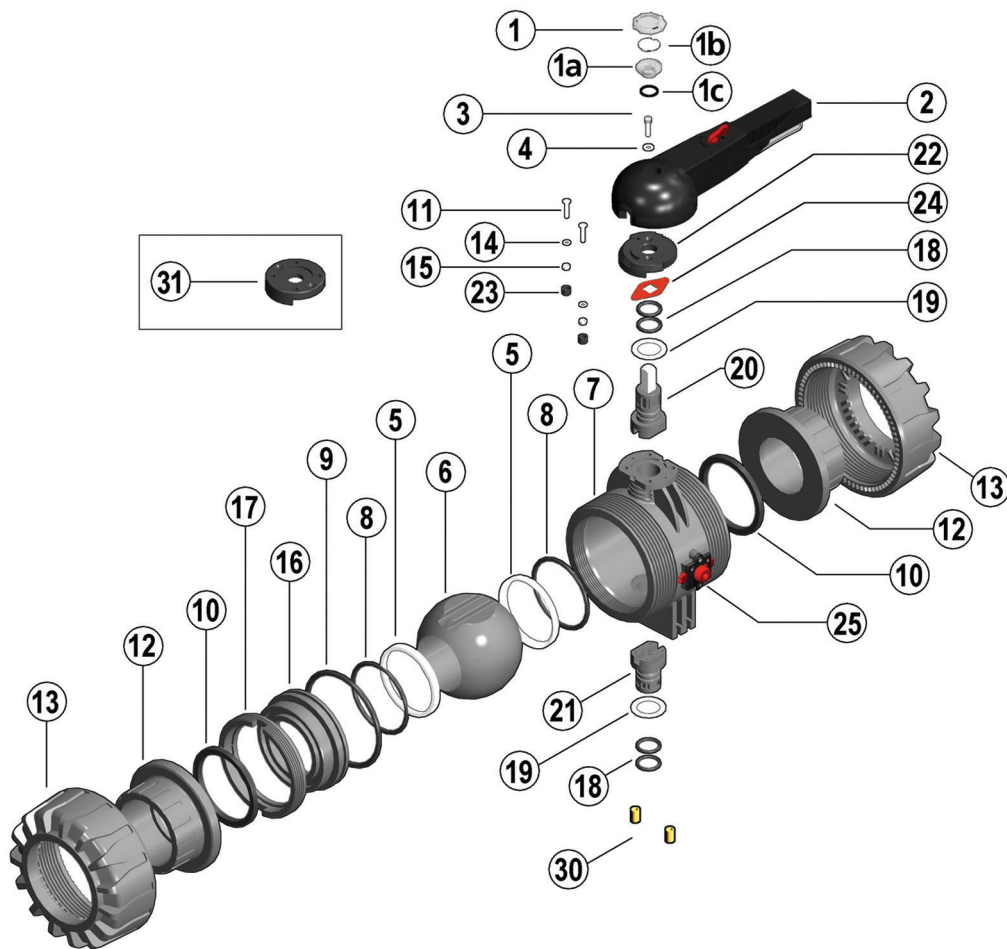

- | | | |
|---|---|--|
| 1-1a Transparent protection plug (PVC - 1) | 9 Radial seal O-Ring (EPDM - FKM - 1)* | 18 Stems O-rings (EPDM-FKM - 4)* |
| 1b Tag holder (PVC - 1) | 10 Socket seal O-Ring (EPDM-FKM - 2)* | 19 Anti-friction disk(PTFE - 2)* |
| 1c O-Ring (NBR - 1) | 11 Screw (STAINLESS steel - 2) | 20 Upper stem (PVC/INOX - 1) |
| 2 Handle (HIPVC - 1) | 12 End connector (PVC-U - 2) | 21 Lower stem (PVC-U - 1) |
| 3 Screw (STAINLESS steel - 1) | 13 Union nut (PVC-U - 2) | 22 Plate (PP-GR - 1) |
| 4 Washer (STAINLESS steel - 1) | 14 Washer (STAINLESS steel - 2) | 23 Protection plug (PE - 2) |
| 5 Ball seat (PTFE - 2)* | 15 Nut (STAINLESS steel - 2) | 24 Position indicator (PA - 1) |
| 6 Ball (PVC-U - 1) | 16 Ball seat carrier (PVC-U - 1) | 25 DUAL BLOCK® (PP-GR + vari- 1) |
| 7 Body (PVC-U - 1) | 17 Threaded ring (PVC-U - 1) | 30 Threaded inserts (Brass - 2)** |
| 8 Ball seat O-ring (EPDM-FKM - 2)* | | 31 Actuation plate (PP-GR - 1)** |

* Spare parts

** Accessories

The component material and quantity supplied are indicated in the parentheses.

DISASSEMBLY

- 1) Isolate the valve from the line (release the pressure and empty the pipeline).
- 2) Release the union nuts by rotating the button (25) to the left, pointing the arrow on the open lock (fig. 1).
- 3) Unscrew the union nuts (13) and extract the body (7) (fig. 2).
- 4) Before dismantling, hold the valve in a vertical position and open it 45° to drain any liquid that might remain.
- 5) Open the valve.
- 6) Remove the protection plug on the handle (2) and unscrew the screw (3) with the washer (4).
- 7) Remove the handle (2).
- 8) Remove the screws (11) and plate (22) from the body (7).
- 9) Insert the two supplied wrench protrusions in the corresponding apertures on the threaded ring (17), extracting it by rotating counterclockwise with the ball seat carrier (16) (fig. 3).
- 10) Press on the ball (6), being careful not to scratch it, and remove it from the body.
- 11) Press the upper stem (20) inwards and extract it from the body and remove the lower stem (21). Remove the anti-friction disks (19).
- 12) Remove the O-Ring (8, 9, 10, 18) and PTFE ball seats (5) extracting them from their housings, as illustrated in the exploded view.

ASSEMBLY

- 1) All the O-rings (8, 9, 10, 18) must be inserted in their grooves as shown in the exploded view.
- 2) Place the anti-friction disks (19) on the stems (20-21) and insert the stems in their housings in the body.
- 3) Place the PTFE ball seats (5) in the housings in the valve body (7) and in the carrier (16).
- 4) Insert the ball (6) rotating it to the closed position.
- 5) Insert the carrier with threaded ring (17) into the body and tighten up in the clockwise direction using the supplied tool, to limit stop.
- 6) Position the plate (22) with rack on the body, and screw in the screws (11) washers (14) and nuts (15).
- 7) The handle (2) with protection plug (1, 1a, 1b, 1c) should be placed on the stem (20) (fig. 4).
- 8) Screw in the screw (3) with the washer (4) and position the protection plug (1, 1a, 1b, 1c).
- 9) Insert the valve between the end connectors (12) and tighten the union nuts (13), making sure that the socket seal O-rings (10) do not exit their seats.
- 10) Release the union nuts by rotating the button (25) to the right, pointing the arrow on the closed lock (fig. 1).



Note: during assembly operations, it is advisable to lubricate the rubber seals. Mineral oils are not recommended for this task as they react aggressively with EPDM rubber.

Fig. 1



Fig. 2



Fig. 3



Fig. 4



INSTALLATION

Before proceeding with installation, please follow these instructions carefully:

- 1) Check that the pipes to be connected to the valve are aligned in order to avoid mechanical stress on the threaded joints.
- 2) Make sure the DUAL BLOCK® union nut lock system (25) is in the FREE position.
- 3) Unscrew the union nuts (13) and insert them on the pipe segments.
- 4) Solvent weld or screw the end connectors (12) onto the pipe ends.
- 5) Position the valve body between the end connectors and fully tighten the union nuts (13) clockwise with an appropriate wrench.
- 6) Lock the union nuts rotating the button (25) clockwise (see paragraph "union nut lock").
- 7) If necessary, support the piping with FIP pipe clips or by means of the carrier built into the valve itself (see paragraph "fastening and supporting").

Adjust the ball seat carriers using the supplied tool (fig. 3).

The seals can be installed later with the valve installed on the pipe by simply tightening the union nuts. This "micro adjustment", only possible with FIP valves thanks to the patented "Seat stop system", allows the seal to be recovered where PTFE ball seats are worn due to a high number of operations.

UNION NUT LOCK

Rotate the button to the left, pointing the arrow on the open lock to unlock DUAL BLOCK®: the valve union nuts are free to rotate clockwise and counter-clockwise. Rotate the button to the right, pointing the arrow on the closed lock to lock DUAL BLOCK®: the valve union nuts are blocked in the desired position.

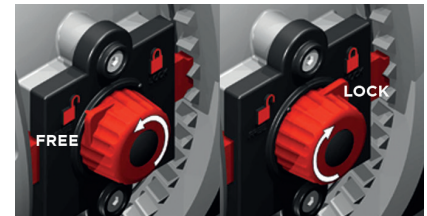

HANDLE LOCK

Thanks to the multifunctional handle and the red manoeuvre button on the lever, you can perform a 0°-90° operation and a graduated operation by means of the 10 intermediate positions and a stop lock: the handle can be locked in each of the 10 positions by simply pressing the Free-lock button. A lock can also be installed on the handle to protect the system against tampering. The valve is two-way and can be installed in any position. It can also be installed at end line or tank.



WARNINGS

If volatile liquid such as Hydrogen Peroxide (H₂O₂) or Sodium Hypochlorite (NaClO) are used, for safety reasons we recommend you contact the service centre. These liquids, upon vaporising, could create hazardous over pressures in the area between the body and ball.

Always avoid sudden closing operations and protect the valve from accidental operations.