

VR DN 10÷100

Check valve



VR DN 10÷100

The VR is an angle seat check valve with weighted PVC piston that allows the passage of fluid in one direction only.

CHECK VALVE

- Connection system for solvent weld, threaded and flanged joints
- **No metal parts in contact with the fluid**
- **Piston with counterweight** able to work with high intensity fluid
- Limited pressure drop. Only minimum back pressure is required for the hermetic seal
- **Valve material compatibility** (PVC-U) with water conveyance, drinking water and other food substances according to **current regulations**
- Can be maintained with the valve body installed

Technical specifications	
Construction	Angle seat check valve
Size range	DN 10 ÷ 100
Nominal pressure	DN 10÷50: PN 16 with water at 20 °C DN 65 PN 10 with water at 20 °C DN 80÷100: PN 6 with water at 20 °C
Temperature range	0 °C ÷ 60 °C
Coupling standards	Solvent welding: EN ISO 1452, EN ISO 15493, BS 4346-1, , NF T54-028, ASTM D 2467, JIS K 6743. Can be coupled to pipes according to EN ISO 1452, EN ISO 15493, DIN 8062, NF T54-016, ASTM D 1785, JIS K 6741. Thread: ISO 228-1, EN 10226-1/2, ASTM D 2464, JIS B 0203. Flanging system: ISO 7005-1, EN ISO 1452, EN ISO 15493, EN 558-1 (DN 10÷50) , EN 1092-1, ANSI B.16.5 cl. 150, JIS B 2220.
Reference standards	Construction criteria: EN ISO 16137 EN ISO 1452, EN ISO 15493 Test methods and requirements: ISO 9393 Installation criteria: DVS 2204, DVS 2221, UNI 11242
Valve material	PVC-U
Seal material	EPDM or FKM

TECHNICAL DATA

PRESSURE VARIATION ACCORDING TO TEMPERATURE

For water and non-hazardous fluids with regard to which the material is classified as CHEMICALLY RESISTANT. In other cases, a reduction of the nominal pressure PN is required (25 years with safety factor).

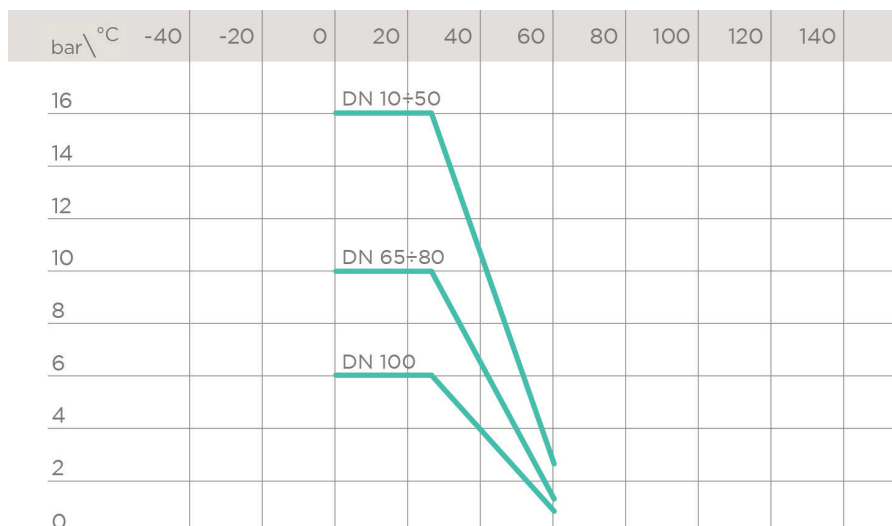

PRESSURE DROP GRAPH

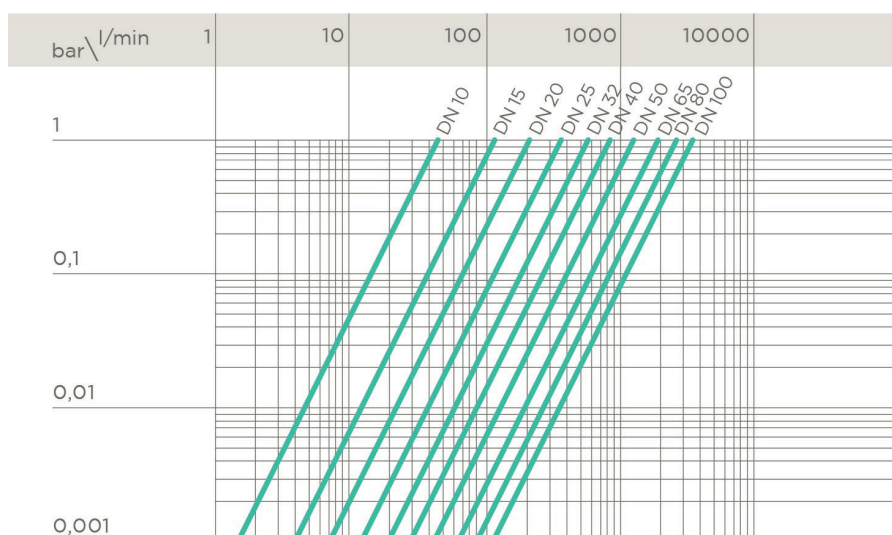

K_v100 FLOW COEFFICIENT

The K_v100 flow coefficient is the Q flow rate of litres per minute of water at a temperature of 20°C that will generate Δp= 1 bar pressure drop at a certain valve position. The Kv100 values shown in the table are calculated with the valve completely open.

DN	10	15	20	25	32	40	50	65	80	100
Kv100 l/min	47	110	205	375	560	835	1300	1950	2600	3500

MINIMUM PRESSURE REQUIRED TO LIFT THE PISTON

DN	10	15	20	25	32	40	50	65	80	100
bar	0,008	0,008	0,009	0,014	0,017	0,018	0,021	0,022	0,022	0,024

MINIMUM SEALING PRESSURE (PISTON IN CLOSED POSITION)

DN	10	15	20	25	32	40	50	65	80	100
mm	150	150	200	350	350	350	350	350	350	350
H ₂ O										

The figures refer to the seals that are not worn.

DIMENSIONS

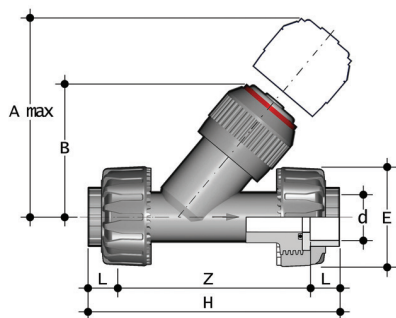

VRUIV

Check valve with female union ends for solvent welding, metric series

d	DN	PN	A max	B	E	H	L	Z	Fig.	g	EPDM code	FKM code
16	10	16	125	72	55	135	14	107	A	218	VRUIV016E	VRUIV016F
20	15	16	125	72	55	135	16	103	A	226	VRUIV020E	VRUIV020F
25	20	16	145	84	66	158	19	120	A	388	VRUIV025E	VRUIV025F
32	25	16	165	95	75	176	22	132	A	606	VRUIV032E	VRUIV032F
40	32	16	190	111	87	207	26	155	A	923	VRUIV040E	VRUIV040F
50	40	16	210	120	100	243	31	181	A	1335	VRUIV050E	VRUIV050F
63	50	16	240	139	120	298	38,2	221,6	A	2313	VRUIV063E	VRUIV063F

disponibile anche con connessioni standard, ANSI, BS e JIS

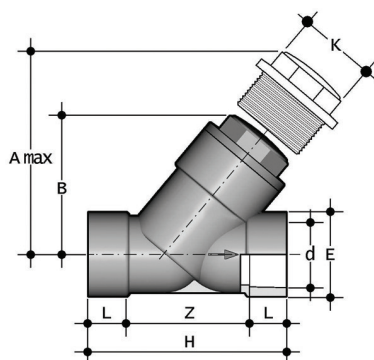

VRIV

Check valve with female ends for solvent welding, metric series

d	DN	PN	A max	B	E	H	K	L	Z	Fig.	g	EPDM code
75	65	10	300	179	104	243	96	44	155	B	3485	VRIV075E
90	80	6	325	192	116	262	105	51	160	B	4530	VRIV090E
110	100	6	385	231	138	325	-	61	203	C	7170	VRIV110E

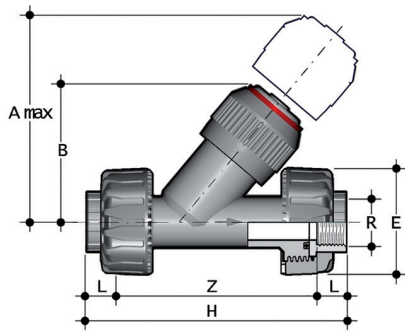

VRUFV

Check valve with BSP threaded female union ends

R	DN	PN	A max	B	E	H	L	Z	Fig.	g	EPDM code
3/8"	10	16	125	72	55	135	11,4	112,2	A	221	VRUFV038E
1/2"	15	16	125	72	55	143	15	113	A	230	VRUFV012E
3/4"	20	16	145	84	66	160	16,3	127,4	A	390	VRUFV034E
1"	25	16	165	95	75	183	19,1	144,8	A	602	VRUFV100E
1" 1/4	32	16	190	111	87	214	21,4	171,2	A	932	VRUFV114E
1" 1/2	40	16	210	120	100	235	21,4	192,2	A	1341	VRUFV112E
2"	50	16	240	139	120	285	25,7	233,6	A	2348	VRUFV200E

disponibile anche con connessioni standard, ASTM/NPT

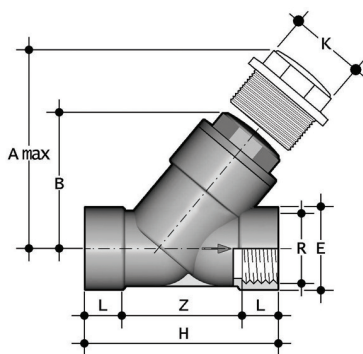

VRFV

Check valve with BSP threaded female ends

R	DN	PN	A max	B	E	H	K	L	Z	Fig.	g	EPDM code
2" 1/2	65	10	300	179	104	243	96	30,2	182,6	B	3485	VRFV212E
3"	80	6	325	192	116	262	105	33,3	195,4	B	4520	VRFV300E
4"	100	6	385	231	138	325	-	39,3	246,4	C	6965	VRFV400E

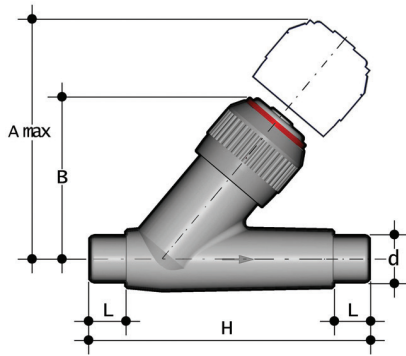

VRDV

Check valve with male ends for solvent welding, metric series

d	DN	PN	A max	B	H	L	Fig.	g	EPDM code
16	10	16	125	72	114	14	A	125	VRDV016E
20	15	16	125	72	124	16	A	135	VRDV020E
25	20	16	145	84	144	19	A	225	VRDV025E
32	25	16	165	95	154	22	A	360	VRDV032E
40	32	16	190	111	174	26	A	590	VRDV040E
50	40	16	210	120	194	31	A	835	VRDV050E
63	50	16	240	139	224	38	A	1420	VRDV063E

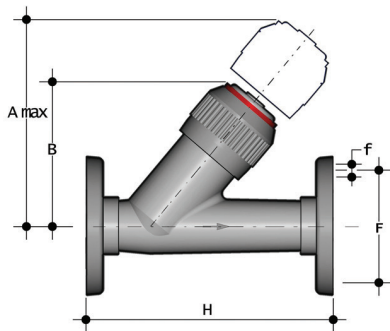

VROV D 20 ÷ 63

Check valve with fixed flanges, drilled PN10/16

d	DN	PN	A max	B	F	f	H	Fig.	g	EPDM code	FKM code
20	15	16	125	72	65	14	130	A	280	VROV020E	VROV020F
25	20	16	145	84	75	14	150	A	430	VROV025E	VROV025F
32	25	16	165	95	85	14	160	A	640	VROV032E	VROV032F
40	32	16	190	111	100	18	180	A	1035	VROV040E	VROV040F
50	40	16	210	120	110	18	200	A	1405	VROV050E	VROV050F
63	50	16	240	139	125	18	230	A	2235	VROV063E	VROV063F

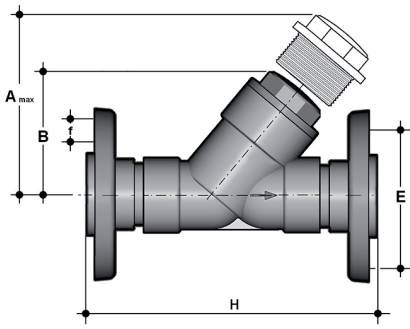

VROV D 75 ÷ 110

Check valve with PVC-U backing ring, drilled PN10/16

d	DN	PN	A max	B	F	f	H	Fig.	g	EPDM code	FKM code
75	65	10	300	179	145	17	356	B	4600	VROV075E	VROV075F
90	80	6	325	192	160	17	404	B	6300	VROV090E	VROV090F
110	100	6	385	231	180	17	475	C	9200	VROV110E	VROV110F

COMPONENTS

EXPLODED VIEW

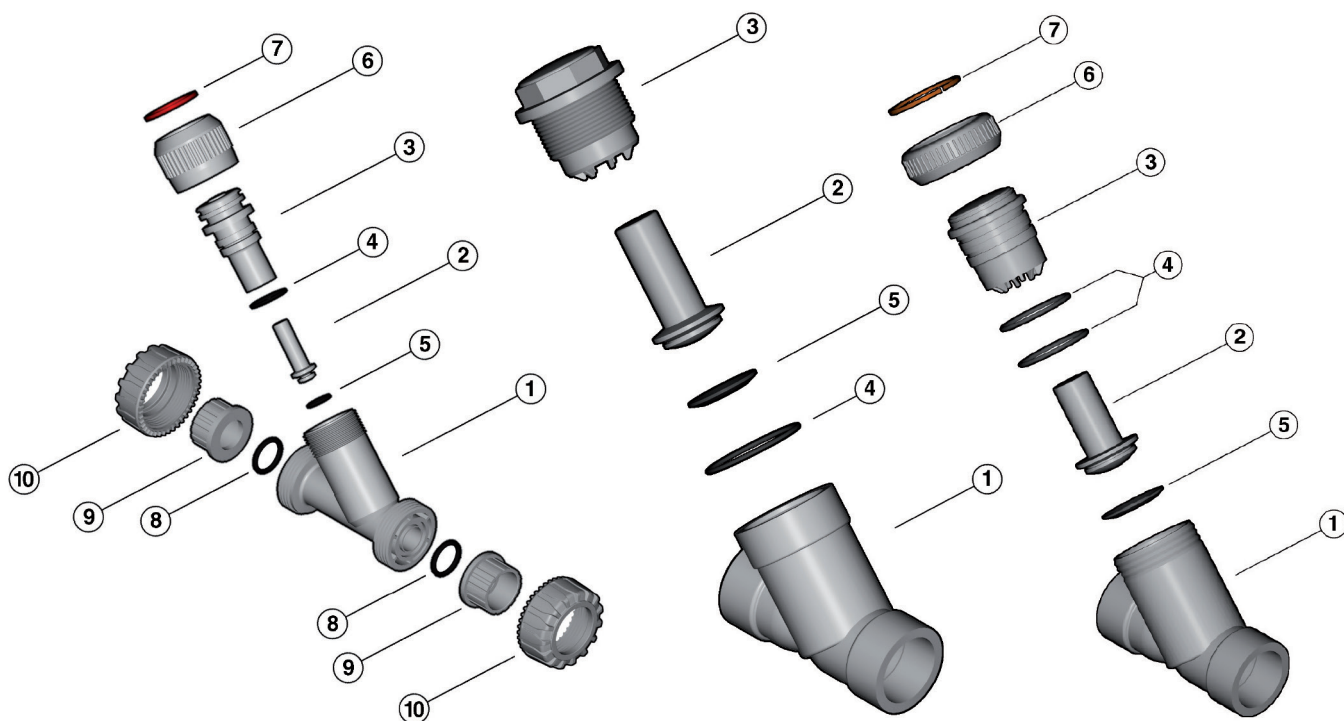

DN 15÷50

DN 65÷80

DN 100

- | | | |
|-----------------------------------|---|---|
| 1 Body (PVC-U - 1) | 5 Piston flat gasket (EPDM-FKM - 1)* | 8 Socket seal O-Ring (EPDM-FKM - 2)* |
| 2 Piston (PVC-U - 1) | 6 Union nut (PVC-U - 1) | 9 End connector (PVC-U - 2)* |
| 3 Bonnet (PVC-U - 1) | 7 Retaining ring (PVC-U - 1) | 10 Union nut (PVC-U - 2) |
| 4 O-Ring (EPDM-FKM - 1/2)* | | |

* Spare parts

The material of the component and the quantity supplied are indicated between brackets

DISASSEMBLY

DN 15÷50 - DN 100 (FIG. A E C)

- 1) Isolate the valve from the fluid flow.
- 2) Unscrew the union nut (6) and separate the bonnet (3) from the body (1).
- 3) Remove the piston (2) and flat gasket (5).
- 4) Remove the retaining ring (7) and separate the union nut (6) from the bonnet (3).
- 5) Remove the O-Ring from the bonnet (4).

DN 65÷100 (FIG. B)

- 1) Isolate the valve from the fluid flow.
- 2) Unscrew the bonnet (3) from the body (1).
- 3) Remove the O-Ring (4) from its seating in the body (1).
- 4) Remove the piston (2) and relative flat gasket (5).

ASSEMBLY

DN 15÷50 - DN 100 (FIG. A E C)

- 1) Insert the O-Ring (4) in its seating in the bonnet (3).
- 2) Insert the bonnet (3) in union nut (6) and fix the two components using the retaining ring (7).
- 3) Insert the piston (2) complete with flat gasket (5) in the bonnet (3), then fit the bonnet on the body (1).
- 4) Screw the union nut (6) on the body (1)

DN 65÷100 (FIG. B)

- 1) Insert the piston (2) complete with flat gasket (5) in the bonnet (3).
- 2) Insert the O-ring (4) in the body (1) seating.
- 3) Screw the bonnet (3) to the body (1)



Note: maintenance operations can be carried out with the valve body installed during assembly, it is advisable to lubricate the rubber seals. Mineral oils are not recommended for this task as they react aggressively with EPDM rubber.

Fig. A

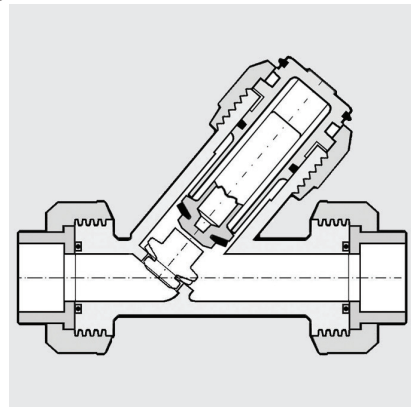

Fig. B

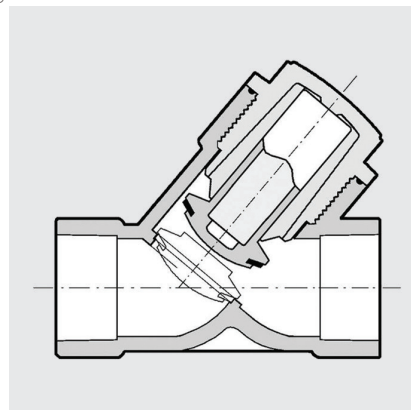
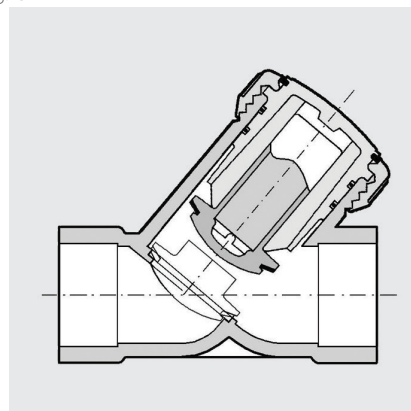

Fig. C



INSTALLATION

The check valve can be installed on vertical or horizontal axis pipes. The bonnet (3) must however always be turned upwards as the piston works by gravity.

If the valve is installed in a vertical position, if the connection is solvent welded, make sure that the solvent cement does not enter inside the body, as this would damage the seating of the seal.

Install the valve such that the arrow stamped on the body indicates the direction of fluid flow .

WARNINGS

Do not use compressed air or other gases to test thermoplastic lines.

Leave a straight section of pipe of length equal to 5 times the nominal diameter before and after the valve