



FITTINGS FOR SOCKET WELDING

PVDF

Fittings, metric series ISO-UNI



FITTINGS FOR SOCKET WELDING

Series of fittings designed for conveying fluids under pressure with a hot weld connection system (socket welding).

FITTINGS, METRIC SERIES ISO-UNI

Technical specifications	
Size range	d 16÷ 110 (mm)
Nominal pressure	PN 16 with water at 20° C
Temperature range	-40 °C ÷ 140 °C
Coupling standards	Welding: EN ISO 10931. Can be coupled to pipes according to EN ISO 10931 Flanging system: ISO 7005-1, EN 10931, EN 558-1, DIN 2501, ANSI B.16.5 cl. 150
Reference standards	Construction criteria: EN ISO 10931 Test methods and requirements: EN ISO 10931 Installation criteria: DVS 2201-1, DVS 2207-15, DVS 2208-1
Fitting material	PVDF
Seal material	FKM

TECHNICAL DATA

REGRESSION CURVES FOR FITTINGS IN PVDF

Regression coefficients according to ISO 10931 for MRS (minimum) = 25 N/mm² (MPa)

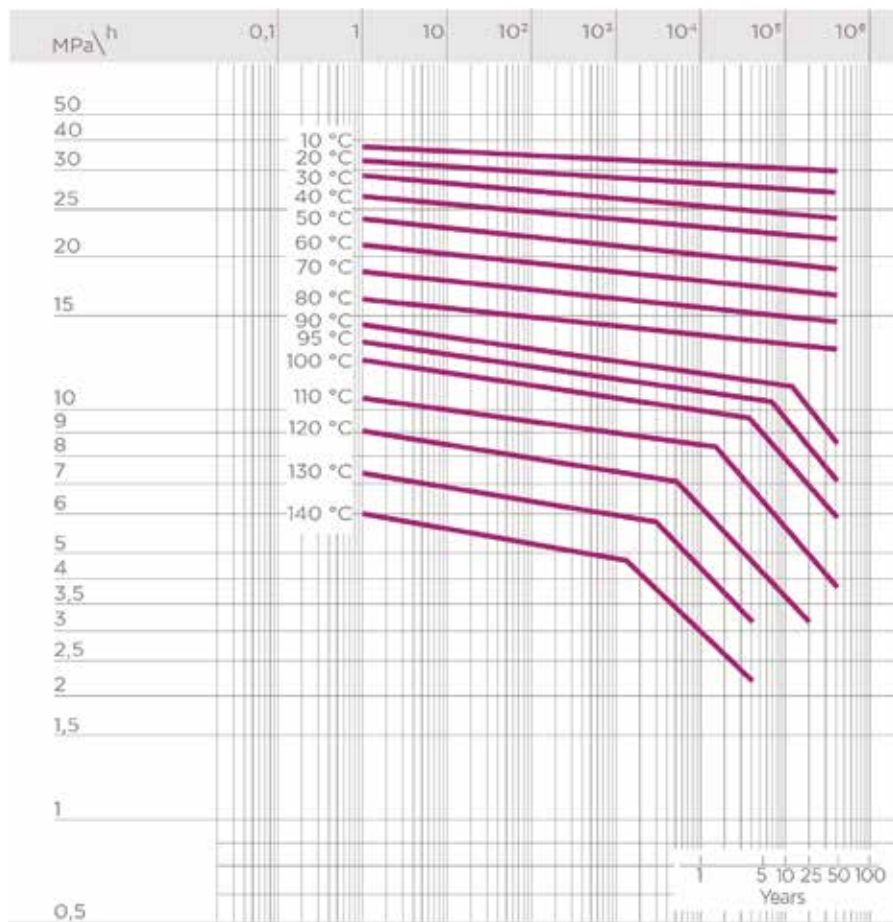

PRESSURE VARIATION ACCORDING TO TEMPERATURE

For water and non-hazardous fluids for which the material is classified as CHEMICALLY RESISTANT (life expectancy 25 years). In other cases, a reduction of the nominal pressure PN is required.

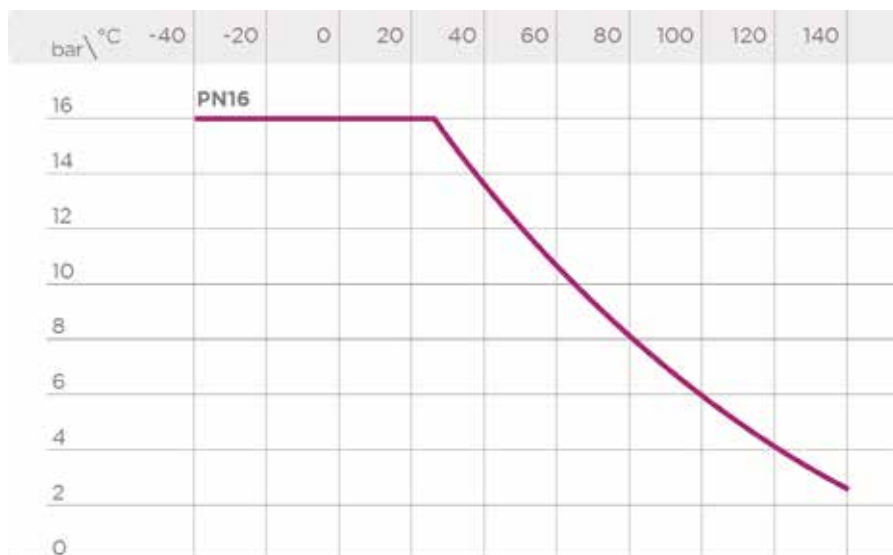

The information in this leaflet is provided in good faith. No liability will be accepted concerning technical data that is not directly covered by recognised international standards. FIP reserves the right to carry out any modification. Products must be installed and maintained by qualified personnel.

DIMENSIONS

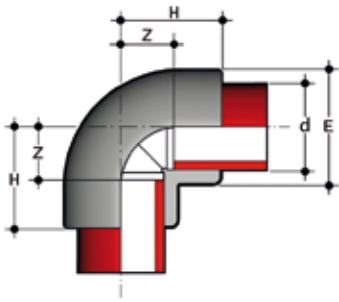

GIF

90° elbow for socket welding

d	PN	E	H	Z	g	Code
16	16	22	23	10	14	GIF016
20	16	28	27	13	28	GIF020
25	16	33	32	16	43	GIF025
32	16	41	37	19	65	GIF032
40	16	52	43	23	125	GIF040
50	16	63	51	27	195	GIF050
63	16	77	61	34	340	GIF063
75	16	92	73	42	575	GIF075
90	16	110	83	47	850	GIF090
110	16	133	99	58	1470	GIF110

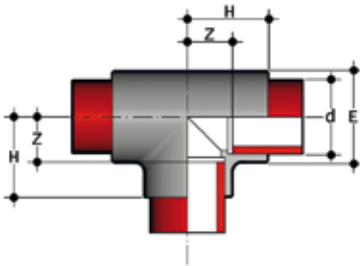

TIF

90° Tee for socket welding

d	PN	E	H	Z	g	Code
16	16	22	23	10	18	TIF016
20	16	28	27	13	35	TIF020
25	16	33	32	16	55	TIF025
32	16	41	37	19	90	TIF032
40	16	51	43	22	150	TIF040
50	16	63	52	29	270	TIF050
63	16	79	63	35	470	TIF063
75	16	93	71	40	665	TIF075
90	16	109	82	46	1025	TIF090
110	16	133	99	58	1800	TIF110

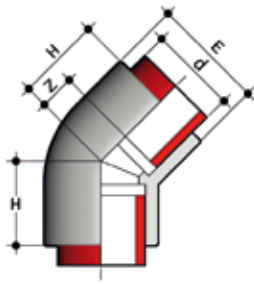

HIF

45° elbow for socket welding

d	PN	E	H	Z	g	Code
20	16	28	22	7	24	HIF020
25	16	33	25	9	37	HIF025
32	16	42	30	12	63	HIF032
40	16	51	37	16	110	HIF040
50	16	63	43	19	202	HIF050
63	16	79	52	25	337	HIF063
75	16	88	61	30	395	HIF075
90	16	105	73	37	645	HIF090
110	16	127	87	46	1095	HIF110

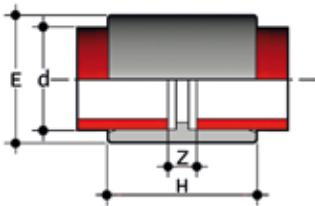

MIF

Double socket for socket welding

d	PN	E	H	Z	g	Code
20	16	28	36	7	20	MIF020
25	16	33	40	8	28	MIF025
32	16	42	44	8	48	MIF032
40	16	51	49	8	70	MIF040
50	16	63	55	8	120	MIF050
63	16	77	64	9	185	MIF063
75	16	90	72	10	275	MIF075
90	16	108	79	8	415	MIF090
110	16	131	84	11	710	MIF110

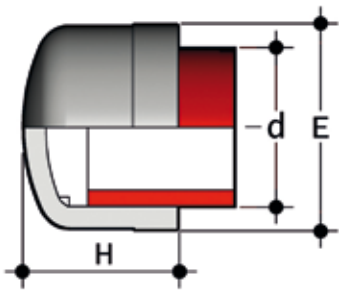

CIF

End cap for socket welding

d	PN	H	E	g	Code
*16	16	20	23	7	CIF016
20	16	23	28	11	CIF020
25	16	27	33	19	CIF025
32	16	31	41	32	CIF032
40	16	36	50	47	CIF040
50	16	43	61	75	CIF050
63	16	51	76	135	CIF063
*75	16	58	90	215	CIF075
*90	16	68	109	400	CIF090
*110	16	81	130	630	CIF110

*Resale product

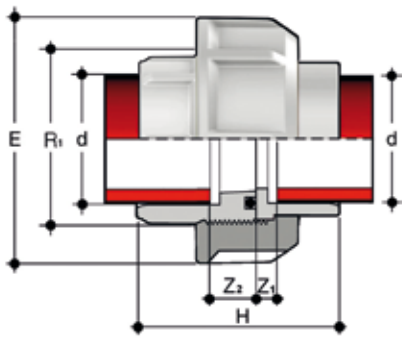

BIGF
Union for socket welding

d	R ₁	PN	E	H	Z1	Z2	g	FKM code
20	1"	16	47	45,5	12	5,5	59	BIGF020F
25	1"1/4	16	58	49,5	12	5,5	99	BIGF025F
32	1"1/2	16	65	53,5	12	5,5	141	BIGF032F
40	2"	16	78	59,5	14	5,5	218	BIGF040F
50	2"1/4	16	85	67,5	16	5,5	290	BIGF050F
63	2"3/4	16	103	79,5	20	5,5	476	BIGF063F

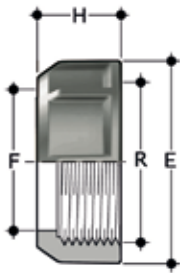

EFGF
Union nut with BSP thread for union types BIGF, BIFXF and BIRXF

R	d BIGF	E	F	H	g	Code
1"	20	47	28	22	30	EFGF100
1"1/4	25	58	36	25	46	EFGF114
1"1/2	32	65	42	27	63	EFGF112
2"	40	78	53	30	90	EFGF200
2"1/4	50	85	59	33	117	EFGF214
2"3/4	63	103	74	38	188	EFGF234

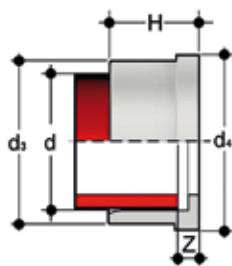

Q/BIGF

Union end for socket welding, metric series

d	PN	d ₃	d ₄	H	Z	g	Code
20	16	27,5	30,1	19,5	5,5	13	QBIGF020
25	16	36	38,8	21,5	5,5	27	QBIGF025
32	16	41,5	44,7	23,5	5,5	32	QBIGF032
40	16	53	56,5	25,5	5,5	57	QBIGF040
50	16	59	62,6	28,5	5,5	57	QBIGF050
63	16	74	78,4	32,5	5,5	97	QBIGF063

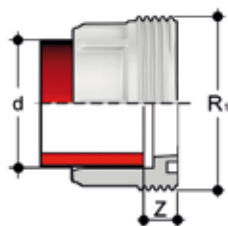

F/BIGF

Union bush for socket welding, metric series

d	R ₁	PN	Z	g	Code
20	1"	16	12	16	FBIGF020
25	1 1/4"	16	12	27	FBIGF025
32	1 1/2"	16	12	38	FBIGF032
40	2"	16	14	62	FBIGF040
50	2 1/4"	16	16	74	FBIGF050
63	2 3/4"	16	18	141	FBIGF063

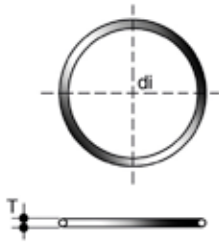

O-RING

Seals for union types BIGF, BIFXF and BIRXF

d union	C	di	T	EPDM code	FKM code
16	3062	15,54	2,62	OR3062E	OR3062F
20	4081	20,22	3,53	OR4081E	OR4081F
25	4112	28,17	3,53	OR4112E	OR4112F
32	4131	32,93	3,53	OR4131E	OR4131F
40	6162	40,65	5,34	OR6162E	OR6162F
50	6187	47	5,34	OR6187E	OR6187F
63	6237	59,69	5,34	OR6237E	OR6237F
75	6300	75,57	5,34	OR6300E	OR6300F
90	6362	91,45	5,34	OR6362E	OR6362F
110	6450	113,67	5,34	OR6450E	OR6450F

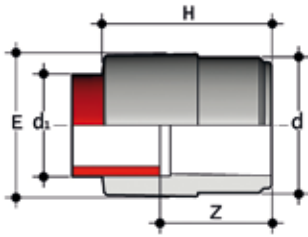

RIF

Reducer: spigot (d), reduced socket for socket welding (d1)

d x d ₁	PN	E	H	Z	g	Code
20 x 16	16	20	35	22	11	RIF020016
25 x 20	16	26	40	26	15	RIF025020
32 x 25	16	32	46	30	28	RIF032025
40 x 25	16	32	51	35	40	RIF040025
40 x 32	16	40	54	36	47	RIF040032
50 x 32	16	39	59	41	55	RIF050032
50 x 40	16	47	63	43	70	RIF050040
63 x 32	16	40	67	49	100	RIF063032
63 x 50	16	60	76	53	130	RIF063050
75 x 63	16	75	89	61	220	RIF075063
90 x 63	16	73	97	70	280	RIF090063
90 x 75	16	87	104	73	335	RIF090075
110 x 90	16	103	121	85	520	RIF110090

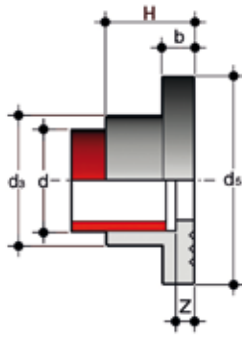

QRNF

Stub with serrated face (according to DIN standards) for socket welding, for use with backing rings ODB

d	DN	PN	b	d ₃	d ₂	H	Z	g	Code
20	15	16	7	27	45	20	6	23	QRNF020
25	20	16	9	34	58	22	6	46	QRNF025
32	25	16	10	41	68	25	6	58	QRNF032
40	32	16	11	50	78	27	6	91	QRNF040
50	40	16	12	61	88	30	6	122	QRNF050
63	50	16	14	76	102	34	6	181	QRNF063
75	65	16	16	90	122	38	7	288	QRNF075
90	80	16	17	108	138	44	8	411	QRNF090
110	100	16	18	131	158	50	8	573	QRNF110

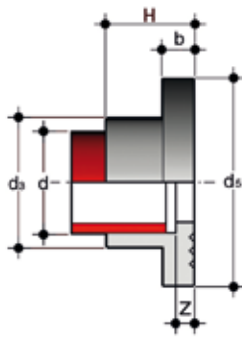

QRAF

Stub with serrated face for socket welding, for used with backing rings OAB (for other dimensions use QRNF)

d	DN	OAB size	PN	b	d ₃	d ₂	H	Z	g	Code
25	20	3/4"	16	9	34	54	22	6	46	QRAF034
32	25	1"	16	10	41	64	25	6	58	QRAF100
40	32	1 1/4"	16	11	50	72	27	6	91	QRAF114
50	40	1 1/2"	16	12	61	83	30	6	122	QRAF112
90	80	3"	16	17	108	129	44	8	411	QRAF300

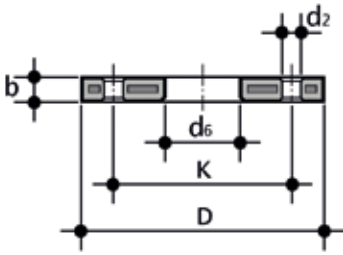

ODB

Steel core backing ring, PP/FRP coated, according to EN/ISO/DIN for stub QRNF. Drilling: PN 10/16

d	DN	*PMA (bar)	b	D	d ₂	d ₆	K	M	** (Nm)	n	g	Code
20	15	16	12	95	14	28	65	M12	15	4	290	ODB020
25	20	16	14	105	14	34	75	M12	15	4	410	ODB025
32	25	16	16	115	14	42	85	M12	15	4	610	ODB032
40	32	16	16	140	18	51	100	M16	20	4	880	ODB040
50	40	16	16	150	18	62	110	M16	30	4	810	ODB050
63	50	16	19	165	18	78	125	M16	35	4	940	ODB063
75	65	16	19	188	18	92	145	M16	40	4	1210	ODB075
**90	80	16	21	200	18	109	160	M16	40	8	1480	ODB090
***125	100	16	20	220	18	135	180	M16	45	8	1570	ODB125

*PMA maximum admissible working pressure

**nominal tightening torque

***d125: for stubs QRNF d 110

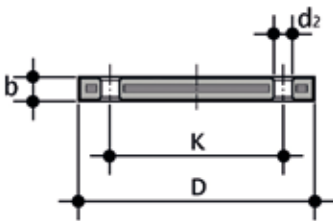

ODBC

Steel core blind flange, PP/FRP according to EN/ISO/DIN Drilling: PN 10/16

d	DN	*PMA (bar)	b	d ₂	D	k	M	n	** (Nm)	g	Code
20	15	10	16	14	95	65	M12	4	15	290	ODBC020S
25	20	10	12	18	105	75	M12	4	15	380	ODBC025S
32	25	10	18	14	115	85	M12	4	15	600	ODBC032S
40	32	10	17	18	140	100	M16	4	25	830	ODBC040S
50	40	10	18	18	150	110	M16	4	35	1105	ODBC050S
63	50	10	18	18	165	125	M16	4	35	1308	ODBC063S
75	65	10	18	18	185	145	M16	4	40	1580	ODBC075S
90	80	10	20	18	200	160	M16	8	40	2244	ODBC090S
110	100	10	20	18	220	180	M16	8	45	2829	ODBC110S

*PMA maximum admissible working pressure

**nominal tightening torque

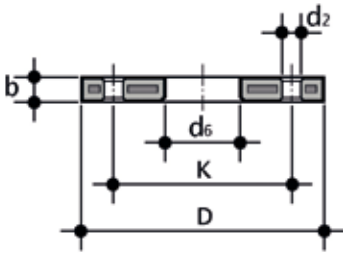

OAB

Steel core backing ring, PP/FRP coated according to ANSI B16.5 cl.150 for stubs QRNF and QRAF

d (inch)	DN	*PMA (bar)	b	D	d ₂ mm	d ₂ inch	d ₆	kmm	k inch	** (Nm)	n	g	Code
1/2"	15	16	12	95	16	5/8"	28	60,45	2"3/8	15	4	220	OAB012
3/4"	20	16	12	102	16	5/8"	34	69,85	2"3/4	15	4	240	OAB034
1"	25	16	16	114	16	5/8"	42	79,25	3"1/8	15	4	390	OAB100
1"1/4	32	16	16	130	16	5/8"	51	88,90	3"1/2	25	4	510	OAB114
1"1/2	40	16	18	133	16	5/8"	62	98,55	3"7/8	35	4	580	OAB112
2"	50	16	18	162	20	3/4"	78	120,65	4"3/4	35	4	860	OAB200
2"1/2	65	16	18	184	20	3/4"	92	139,70	5"1/2	40	4	1100	OAB212
3"	80	16	18	194	20	3/4"	111	152,40	6"	40	4	1040	OAB300
4"	100	16	18	229	20	3/4"	133	190,50	7"1/2	40	8	1620	OAB400

*PMA maximum admissible working pressure

**nominal tightening torque

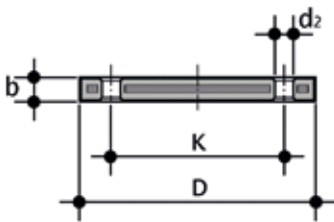

OABC

Steel core blind flange, PP/FRP coated according to ANSI B16.5 cl.150

d (inch)	DN	*PMA (bar)	b	D	d ₂ mm	d ₂ inch	Kmm	Kinch	** (Nm)	n	g	Code
1/2"	15	16	12	95	16	5/8"	60,45	2"3/8	15	4	200	OABC012
3/4"	20	16	12	102	16	5/8"	69,85	2"3/4	15	4	240	OABC034
1"	25	16	16	114	16	5/8"	79,25	3"1/8	15	4	370	OABC100
1"1/4	32	16	16	130	16	5/8"	88,90	3"1/2	25	4	530	OABC114
1"1/2	40	16	18	133	16	5/8"	98,55	3"7/8	35	4	560	OABC112
2"	50	16	18	162	20	3/4"	120,65	4"3/4	35	4	810	OABC200
2"1/2	65	16	18	184	20	3/4"	139,70	5"1/2	40	4	1070	OABC212
3"	80	16	18	194	20	3/4"	152,40	6"	40	4	1030	OABC300
4"	100	16	18	229	20	3/4"	190,50	7"1/2	40	8	1570	OABC400

*PMA maximum admissible working pressure

**nominal tightening torque

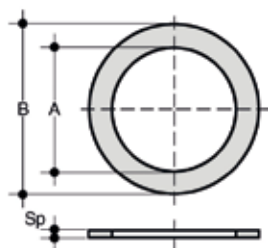

QHV/X

Flat gasket in EPDM and FKM for flanges according to DIN 2501, EN 1092

d	DN	A	B	Sp	EPDM code	FKM code
20 - 1/2"	15	20	32	2	QHVX020E	QHVX020F
25 - 3/4"	20	24	38,5	2	QHVX025E	QHVX025F
32 - 1"	25	32	48	2	QHVX032E	QHVX032F
40 - 1" 1/4	32	40	59	2	QHVX040E	QHVX040F
50 - 1" 1/2	40	50	71	2	QHVX050E	QHVX050F
63 - 2"	50	63	88	2	QHVX063E	QHVX063F
75 - 2" 1/2	65	75	104	2	QHVX075E	QHVX075F
90 - 3"	80	90	123	2	QHVX090E	QHVX090F
110 - 4"	100	110	148	3	QHVX110E	QHVX110F

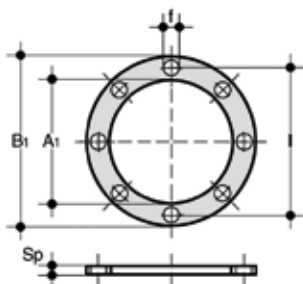

QHV/Y

Flat gasket in EPDM for flanges according to DIN 2501, EN 1092, self-centring for flanges drilled PN 10/16

d	DN	A	B ₁	F	l	U	Sp	Code
20 - 1/2"	15	17	95	14	65	4	2	QHVY020E
25 - 3/4"	20	22	107	14	76,3	4	2	QHVY025E
32 - 1"	25	28	117	14	86,5	4	2	QHVY032E
40 - 1" 1/4	32	36	142,5	18	101	4	2	QHVY040E
50 - 1" 1/2	40	45	153,3	18	111	4	2	QHVY050E
63 - 2"	50	57	168	18	125,5	4	2	QHVY063E
75 - 2" 1/2	65	71	187,5	18	145,5	4	3	QHVY075E
90 - 3"	80	84	203	18	160	8	3	QHVY090E
110 - 4"	100	102	223	18	181	8	3	QHVY110E