



VKR DN 10÷50

PVDF

DUAL BLOCK® regulating ball valve



VKR DN 10÷50

The VKR DUAL BLOCK® valve combines high reliability and safety aspects typical of VKD full bore ball valves with the new flow adjustment function with typical linear curve that meets the most stringent needs typical of industrial applications.



DUAL BLOCK® REGULATING BALL VALVE

- Connection system for weld and flanged joints
- Patented **SEAT STOP®** ball carrier system that lets you micro-adjust ball seats and minimise axial force effects
- Easy radial disassembly allowing quick replacement of O-rings and ball seats without any need for tools
- **PN16 True Union valve body** made for PVDF injection moulding equipped with built-in bores for actuation. ISO 9393 compliant test requisites
- Option of disassembling downstream pipes with the valve in the closed position
- High surface finish stem with double O-Ring and double groove ball connection
- **Integrated bracket** for valve anchoring
- Ball seat carrier can be adjusted using the **Easytorque adjustment kit**
- Actuation option: version with electric modulating actuator with 4-20 mA / 0-10 V inlet and 4-20 mA / 0-10 V outlet to monitor the position
- Valve suitable for carrying fluids that are clean and free of suspended particles

Technical specifications

Construction	2-way True Union regulating ball valve with locked carrier and lockable union nuts
Size range	DN 10 ÷ 50
Nominal pressure	PN 16 with water at 20° C
Temperature range	-40 °C ÷ 140 °C
Coupling standards	Welding: EN ISO 10931 Can be coupled to pipes according to EN ISO 10931 Flanging system: ISO 7005-1, EN ISO 10931, EN 558-1, DIN 2501, ANSI B.16.5 cl. 150
Reference standards	Construction criteria: EN ISO 16135, EN ISO 10931 Test methods and requirements: ISO 9393 Installation criteria: DVS 2202-1, DVS 2207-15, DVS 2208-1 Actuator couplings: ISO 5211
Valve material	PVDF
Seal material	FKM (standard size O-Ring, EPDM on request); PTFE (ball seats)
Control options	Manual control; electric actuator

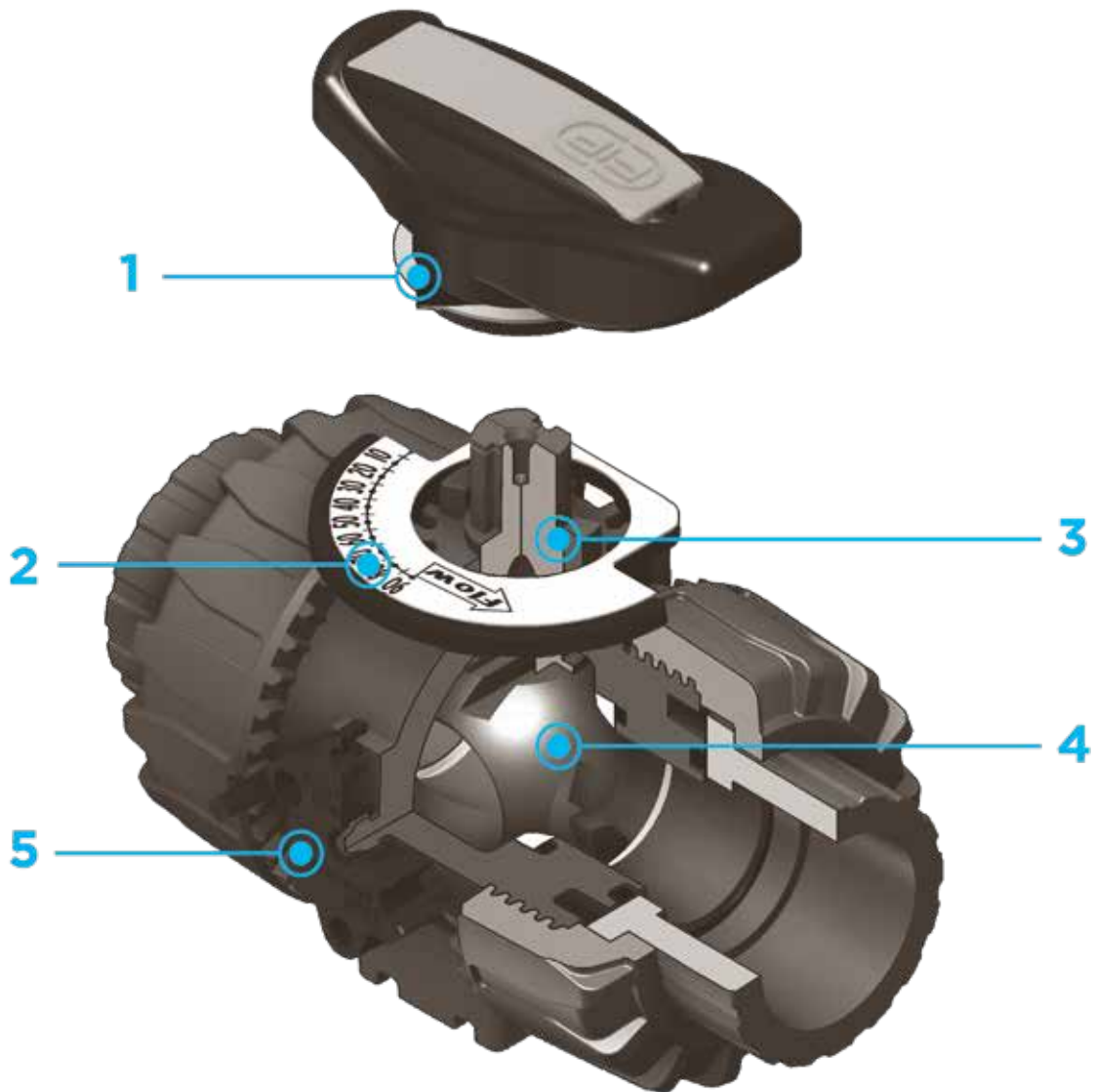

1 HIPVC ergonomic multifunctional handle with **position indicator** and tool to adjust the ball seat carrier

2 Flow direction and opening angle indication plate with **graduated scale with 5° detail** for clear and accurate readings

3 90° operating angle that permits **the use of standard** quarter turn actuators

4 The patented ball design provides **linear flow adjustment** throughout its range of operation even when the valve is open just a few

degrees and guarantees minimum pressure drops

5 Patented **DUAL BLOCK®** system: prevents union nuts from loosening even under extreme operating conditions: e.g. vibration or thermal expansion

TECHNICAL DATA

PRESSURE VARIATION ACCORDING TO TEMPERATURE

For water and harmless fluids to which the material is classified as CHEMICALLY RESISTANT. In other cases, a reduction of the nominal PN pressure is required (25 years with safety factor).

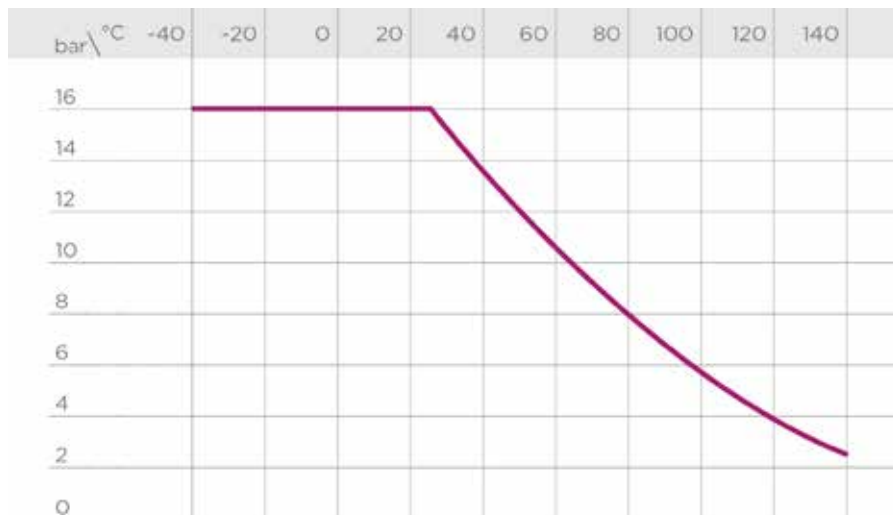

PRESSURE DROP GRAPH

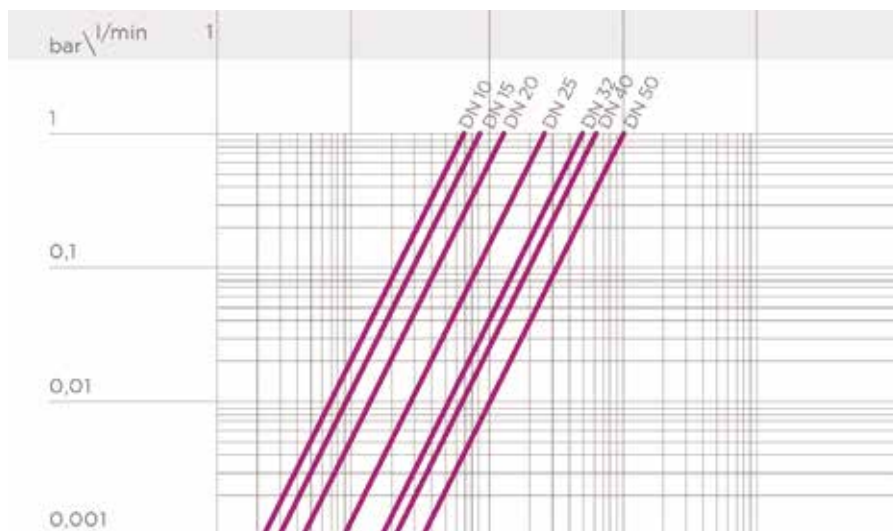

K_v100 FLOW COEFFICIENT

Per coefficiente di flusso K_v100 si intende la portata Q in litri al minuto di acqua a 20°C che genera una perdita di carico Δp= 1 bar per una determinata posizione della valvola.

I valori K_v100 indicati in tabella si intendono per valvola completamente aperta.

DN	10	15	10	25	32	40	50
Kv100 l/min	83	88	135	256	478	592	1068

RELATIVE FLOW COEFFICIENT DIAGRAM

The relative flow coefficient is the flow rate through the valve as a function of the degree of valve aperture.

Horizontal axis: Ball aperture angle
Vertical axis: Relative flow coefficient

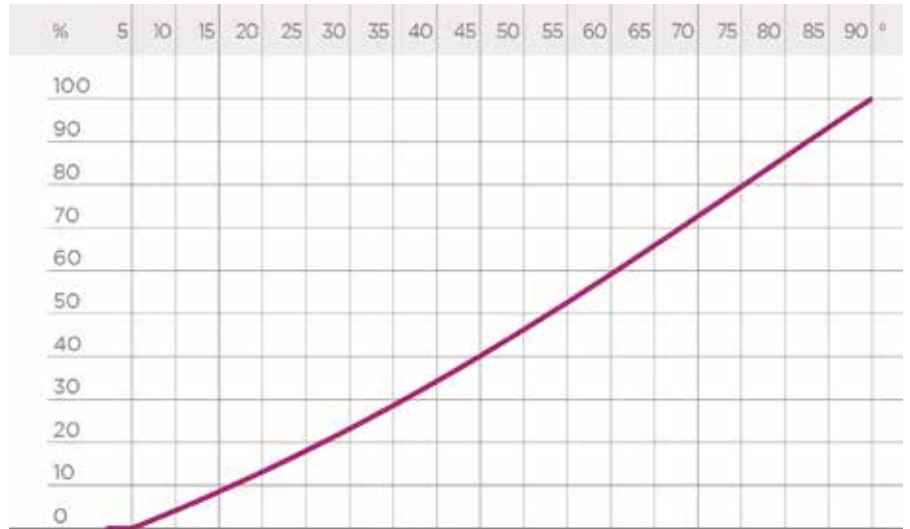

OPERATING TORQUE AT MAXIMUM WORKING PRESSURE

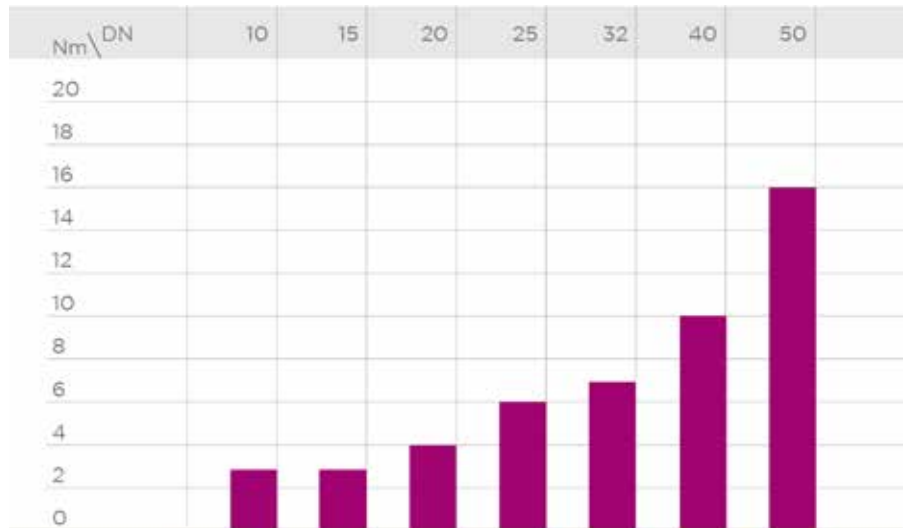

DIMENSIONS

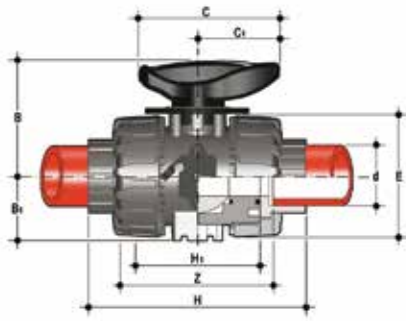

VKRIF

DUAL BLOCK® regulating ball valve with female ends for socket welding, metric series

d	DN	PN	B	B ₁	C	C ₁	E	H	H ₁	Z	g	FKM code
16	10	16	54	29	67	40	54	102	65	74,5	291	VKRIF016F
20	15	16	54	29	67	40	54	102	65	73	272	VKRIF020F
25	20	16	65	34,5	85	49	65	114	70	82	445	VKRIF025F
32	25	16	69,5	39	85	49	73	126	78	90	584	VKRIF032F
40	32	16	82,5	46	108	64	86	141	88	100	938	VKRIF040F
50	40	16	89	52	108	64	98	164	93	117	1242	VKRIF050F
63	50	16	108	62	134	76	122	199	111	144	2187	VKRIF063F

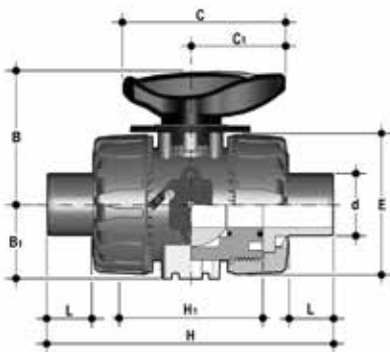

VKRDF

DUAL BLOCK® regulating ball valve with male ends for socket welding, metric series

d	DN	PN	B	B ₁	C	C ₁	E	H	H ₁	L	g	FKM code
20	15	16	54	29	65	40	54	124	65	16	299	VKRDF020F
25	20	16	65	34,5	70	49	65	144	70	18	466	VKRDF025F
32	25	16	69,5	39	78	49	73	154	78	20	604	VKRDF032F
40	32	16	82,5	46	88	64	86	174	88	22	951	VKRDF040F
50	40	16	89	52	93	64	98	194	93	23	1284	VKRDF050F
63	50	16	108	62	111	76	122	224	111	29	2229	VKRDF063F

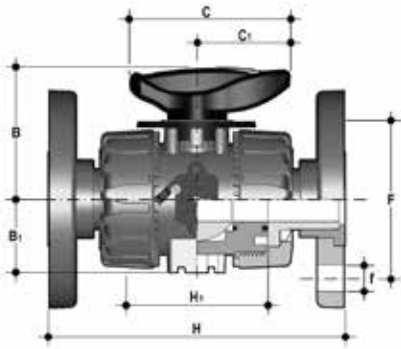

VKROF

DUAL BLOCK® regulating ball valve with EN/ISO/DIN fixed flange, drilled PN10/16. Face to face according to EN 558-1

d	DN	PN	B	B ₁	C	C ₁	F	f	H	H ₁	Sp	U	g	FKM code
20	15	16	54	29	67	40	65	14	130	65	11	4	547	VKROF020F
25	20	16	65	34,5	85	49	75	14	150	70	14	4	772	VKROF025F
32	25	16	69,5	39	85	49	85	14	160	78	14	4	1024	VKROF032F
40	32	16	82,5	46	108	64	100	18	180	88	14	4	1583	VKROF040F
50	40	16	89	52	108	64	110	18	200	93	16	4	2024	VKROF050F
63	50	16	108	62	134	76	125	18	230	111	16	4	3219	VKROF063F

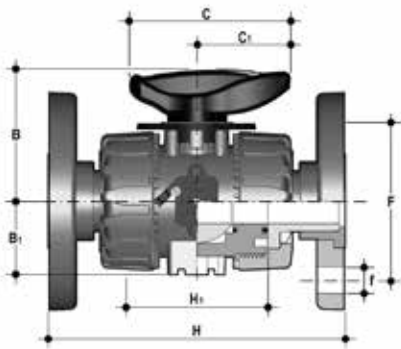

VKROAF

DUAL BLOCK® regulating ball valve with ANSI B16.5 cl.150#FF fixed flange bore

d	DN	PN	B	B ₁	C	C ₁	F	f	H	H ₁	Sp	U	g	FKM code
1/2"	15	16	54	29	67	40	60,3	15,9	143	65	11	4	547	VKROAF012F
3/4"	20	16	65	34,5	85	49	69,9	15,9	172	70	14	4	772	VKROAF034F
1"	25	16	69,5	39	85	49	79,4	15,9	187	78	14	4	1024	VKROAF100F
1" 1/4	32	16	82,5	46	108	64	88,9	15,9	190	88	14	4	1583	VKROAF114F
1" 1/2	40	16	89	52	108	64	98,4	15,9	212	93	16	4	2024	VKROAF112F
2"	50	16	108	62	134	76	120,7	19,1	234	111	16	4	3219	VKROAF200F

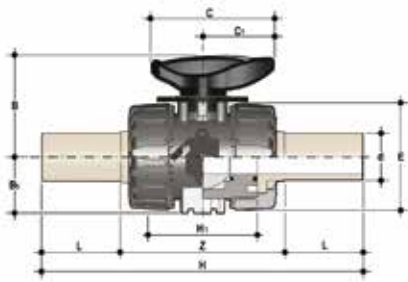

VKRBF

DUAL BLOCK® regulating ball valve with long spigot male ends in PVDF for butt welding/ IR (CVDF)

d	DN	PN	B	B ₁	C	C ₁	E	H	H ₁	L	Z	g	FKM code
20	15	16	54	29	67	40	54	175	65	40,5	94	450	VKRBF020F
25	20	16	65	35	85	49	65	212	70	54	106	516	VKRBF025F
32	25	16	70	39	85	49	73	226	78	56	117	664	VKRBF032F
40	32	16	83	46	108	64	86	246	88	56	131	1020	VKRBF040F
50	40	16	89	52	108	64	98	271	93	60,5	145	1350	VKRBF050F
63	50	16	108	62	134	76	122	300	111	65,5	161	2330	VKRBF063F

ACCESSORIES

CVDF

End connector in PVDF SDR 21 PN 16, long spigot, for butt welding

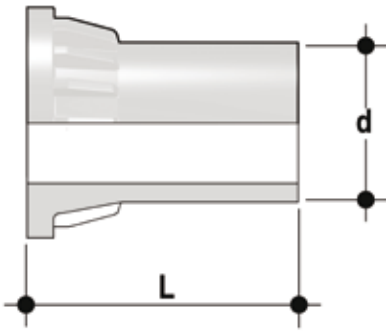

d	DN	PN	L	SDR	Code
20	15	16	55	21	CVDF21020
25	20	16	70	21	CVDF21025
32	25	16	74	21	CVDF21032
40	32	16	78	21	CVDF21040
50	40	16	84	21	CVDF21050
63	50	16	91	21	CVDF21063

PMKD

Wall mounting plate

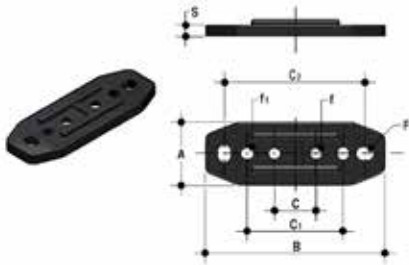

d	DN	A	B	C	C ₁	C ₂	F	f	f ₁	S	Code
16	10	30	86	20	46	67,5	6,5	5,3	5,5	5	PMKD1
20	15	30	86	20	46	67,5	6,5	5,3	5,5	5	PMKD1
25	20	30	86	20	46	67,5	6,5	5,3	5,5	5	PMKD1
32	25	30	86	20	46	67,5	6,5	5,3	5,5	5	PMKD1
40	32	40	122	30	72	102	6,5	6,3	6,5	6	PMKD2
50	40	40	122	30	72	102	6,5	6,3	6,5	6	PMKD2
63	50	40	122	30	72	102	6,5	6,3	6,5	6	PMKD2

Easytorque Kit

Kit for ball seat carrier tightening adjustment for DUAL BLOCK® DN 10-50 series valves



d	DN	Tightening torque recommended*	Code
3/8"-1/2"	10-15	3 N m - 2,21 Lbf ft	KET01
3/4"	20	4 N m - 2,95 Lbf ft	KET01
1"	25	5 N m - 3,69 Lbf ft	KET01
1" 1/4	32	5 N m - 3,69 Lbf ft	KET01
1" 1/2	40	7 N m - 5,16 Lbf ft	KET01
2"	50	9 N m - 6,64 Lbf ft	KET01

*calculated in ideal installation conditions

FASTENING AND SUPPORTING

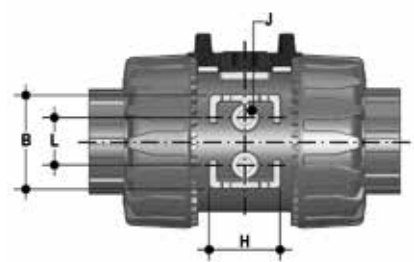

All valves, whether manual or driven, must be adequately supported in many applications.

The VKR valve series is therefore ready to be equipped with threaded supporting brackets (optional) that permits direct anchoring of the valve body without the need of other components.

For wall installation, dedicated PMKD mounting plates which are available as accessories can be used. These plates should be fastened to the valve before wall installation.

PMKD plates also allow VKR valve alignment with FIP ZIKM pipe clips as well as allowing different sizes of valves to be aligned.

d	DN	g	H	L	J*
16	10	31,5	27	20	M4 x 6
20	15	31,5	27	20	M4 x 6
25	20	40	30	20	M4 x 6
32	25	40	30	20	M4 x 6
40	32	50	35	30	M6 x 10
50	40	50	35	30	M6 x 10
63	50	60	40	30	M6 x 10

* With threaded inserts

COMPONENTS

EXPLODED VIEW

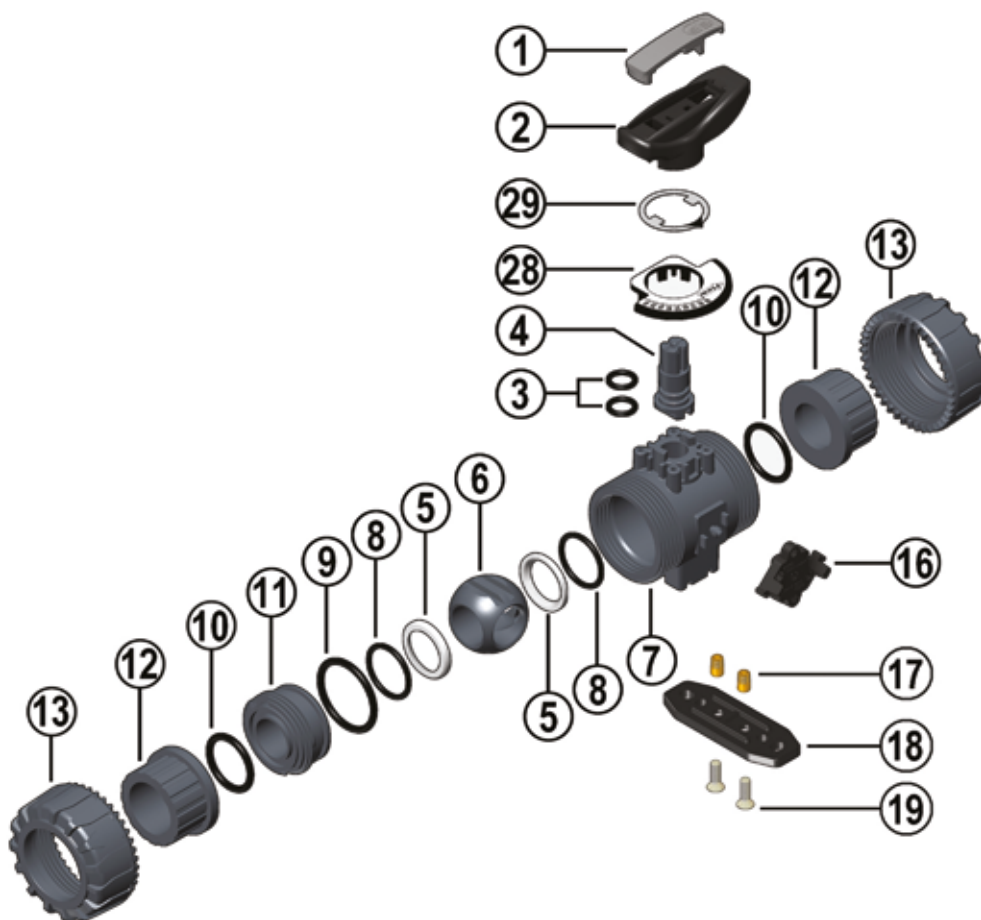

1 Handle insert (PVC - 1)

2 Handle (HIPVC - 1)

3 Stem O-ring (FKM - 2)*

4 Stem (PVDF - 1)

5 Ball seat (PTFE - 2)*

6 Patented ball design (PVDF - 1)

7 Body (PVDF - 1)

8 Ball seat O-Rings (FKM - 2)*

9 Radial seal O-Ring (FKM - 1)*

10 Socket seal O-Ring (FKM - 2)*

11 Ball seat carrier (PVDF - 1)

12 End connector (PVDF - 2)*

13 Union nut (PVDF - 2)

16 DUAL BLOCK® (POM - 1)

17 Threaded inserts (STAINLESS steel or Brass - 2)**

18 Distance plate (PP-GR - 1)**

19 Screw (STAINLESS steel - 2)**

28 Graduated plate (POM-PVC - 1)

29 Indicator (PVC - 1)

* Spare parts

** Accessories

The component material and quantity supplied are indicated in the parentheses.

DISASSEMBLY

- 1) Isolate the valve from the line (release the pressure and empty the pipeline).
- 2) Unlock the union nuts by pressing the lever on the DUAL BLOCK® (16) along the axis and separate it from the union nut (fig. 1). It is also possible to completely remove the block device from the body of the valve.
- 3) Fully unscrew the union nuts (13) and extract the body sideways.
- 4) Before dismounting, hold the valve in a vertical position and open it 45° to drain any liquid that might remain.
- 5) After closing the valve, remove the special insert (1) from the handle (2) and push the two projecting ends into the corresponding recesses on the ball seat carrier (11). Rotate the stop ring anti-clockwise to extract it.
- 6) Pull the handle (2) upwards to remove it from the valve stem (4).
- 7) Make sure that the position indicator (29) remains properly fastened to the handle (2).
- 8) Press on the ball from the side opposite the "REGULAR - ADJUST" label, being sure not to scratch it, until the ball seat carrier exits (11), then extract the ball (6).
- 9) Press the stem (4) inwards until it exits the valve body.
- 10) All the O-rings (3, 8, 9, 10) and PTFE ball seats (5) must be removed from their grooves, as shown in the exploded view.

ASSEMBLY

- 1) All the O-rings (3, 8, 9, 10) must be inserted in their grooves as shown in the exploded view.
- 2) Insert the stem (4) from inside the body (7).
- 3) Place the PTFE ball seats (5) in the housings in the body (7) and in the ball seat carrier (11).
- 4) Insert the ball (6) in the body as shown in Fig. 3
- 5) Screw the carrier (11) into the body and tighten up in the clockwise direction using the special insert (1) to limit stop.
- 6) Position the indicator (29) on the handle with the pointer set to 0 on the graduated scale while making sure that the valve is in the closed position (fig. 2-3).
- 7) Insert the handle (2) with the insert (1) in its housing on the stem (4).
- 8) Insert the valve between the end connectors (12) making sure that they match the direction of flow shown on the plate (fig. 2) then tighten the union nuts (13) making sure that the socket seal O-rings (10) do not come out of their grooves.



Note: during assembly operations, it is advisable to lubricate the rubber seals. Mineral oils are not recommended for this task as they react aggressively with EPDM rubber.

Fig. 1



Fig. 2



Fig. 3



Fig. 4



INSTALLATION

Before proceeding with installation, please follow these instructions carefully:

- 1) Check that the pipes to be connected to the valve are aligned in order to avoid mechanical stress on the threaded joints.
 - 2) Check that the DUAL BLOCK® union nut locking device (16) is fitted to the valve body.
 - 3) To release the union nuts (13), axially press the release lever to separate the lock and then unscrew it in the counter-clockwise direction.
 - 4) Unscrew the union nuts (13) and insert them on the pipe segments.
 - 5) Solvent weld or screw the end connectors (12) onto the pipe ends.
 - 6) Position the valve between the pipe end connectors making sure the that direction of flow is the same as shown on the plate (Fig.4). Hand tighten the union nuts in the clockwise direction. Do not use a wrench or other tools which might damage the surface.
 - 7) Lock the union nuts by returning the DUAL BLOCK® to its housing, pressing on it until the hinges lock on the nuts.
 - 8) If necessary, support the pipework with FIP pipe clips or by means of the carrier built into the valve itself (see paragraph "fastening and supporting").
- Seals can be adjusted using the removable insert on the handle.
The seals can be installed later with the valve installed on the pipe by simply tightening the union nuts. This "micro adjustment", only possible with FIP valves thanks to the patented "Seat stop system", allows the seal to be recovered where PTFE ball seats are worn due to a high number of operations.
The Easytorque kit can also be used for micro adjustments (fig. 5).

Fig. 5



WARNINGS

Always avoid sudden closing operations and protect the valve from accidental operations.